



## **D2.2. TECHNICAL SPECIFICATIONS REPORT OF THE DIFFERENT SPECIES IN WORK ENVIRONMENTS.**

**CoRoSect.eu**



<b>Author(s)/Organisation(s)</b>	TECNOVA
<b>Contributor(s)</b>	ENTOMOTECH
<b>Work Package</b>	WP2.Use-cases, user requirements and system architectures
<b>Delivery Date (DoA)</b>	30/06/2021 (extended)
<b>Actual Delivery Date</b>	08/07/2021
<b>Abstract:</b>	The aim of this deliverable (D2.2: Technical Specifications Report of the Different Species in Work Environments) is to collect scientific information about insects rearing and the three different insect species (Tenebrio molitor, Hermetia illucens and Acheta domesticus) considered in the project in order to create a solid database for a better understanding about the functional specifications of the systems.

<b>Document Revision History</b>			
<b>Date</b>	<b>Version</b>	<b>Author/Contributor/ Reviewer</b>	<b>Summary of main changes</b>
19/05/2021	0	Tecnova/Entomotech	Table of contents
09/06/2021	1	Tecnova/Entomotech	Initial document and sections formatting
21/06/2021	2	Tecnova/Entomotech	Review of the introduction of all information
25/06/2021	3	Tecnova/Entomotech	Modifications from the previous version
29/06/2021	4	Tecnova/Entomotech	Detailed review of the contents and format
30/06/2021	5	Tecnova/Entomotech	Version for internal reviews
02/07/2021	6	ATOS/AGVR	Revised version
08/07/2021	7	Tecnova/Entomotech	Final version

<b>Dissemination Level</b>		
<b>PU</b>	Public	<b>Y</b>
<b>PP</b>	Restricted to other programme participants (including the EC Services)	<b>N</b>
<b>RE</b>	Restricted to a group specified by the consortium (including the EC Services)	<b>N</b>

CO

Confidential, only for members of the consortium (including the EC)

N

Funding Scheme: Innovation Action (IA) • Topic: H2020-ICT-46-2020

Start date of project: 01 January, 2021 • Duration: 36 months

© CoRoSect Consortium, 2021.

Reproduction is authorised provided the source is acknowledged.

CoRoSect Consortium			
Participant Number	Participant organisation name	Short name	Country
1	UNIVERSITEIT MAASTRICHT <a href="https://www.maastrichtuniversity.nl/">https://www.maastrichtuniversity.nl/</a>	UM	NL
2	ETHNIKO KENTRO EREVNAS KAI TECHNOLOGIKIS ANAPTYXIS <a href="https://www.certh.gr/">https://www.certh.gr/</a>	CERTH	GR
3	HOCHSCHULE EMDEN/LEER <a href="https://www.hs-emden-leer.de/en/">https://www.hs-emden-leer.de/en/</a>	HSEL	GER
4	LUONNONVARAKESKUS <a href="https://www.luke.fi/">https://www.luke.fi/</a>	LUKE	FIN
5	OULUN AMMATTIKORKEAKOULU OY - OULU UNIVERSITY OF APPLIED SCIENCES <a href="https://www.oamk.fi/fi/">https://www.oamk.fi/fi/</a>	OAMK	FIN
6	FUNDACION PARA LAS TECNOLOGIAS AUXILIARES DE LA AGRICULTURA <a href="http://www.fundaciontecnova.com/">http://www.fundaciontecnova.com/</a>	TECNOVA	ES
7	KATHOLIEKE UNIVERSITEIT LEUVEN <a href="https://www.kuleuven.be/kuleuven/">https://www.kuleuven.be/kuleuven/</a>	KU LEUVEN	BEL
8	ATOS IT SOLUTIONS AND SERVICES IBERIA SL <a href="https://atos.net/en/">https://atos.net/en/</a>	ATOS	ES
9	ROBOTNIK AUTOMATION SLL <a href="http://www.robotnik.es/">http://www.robotnik.es/</a>	ROB	ES
10	AGVR BV <a href="http://www.agvegroup.com">www.agvegroup.com</a>	AGVR	NL
11	NASEKOMO AD <a href="https://nasekomo.life/">https://nasekomo.life/</a>	NASEKOMO	BG
12	ENTOMOTECH SL <a href="http://entomotech.es/">http://entomotech.es/</a>	ENTOMOTECH	ES
13	ENTOCYCLE LTD <a href="https://www.entocycle.com/">https://www.entocycle.com/</a>	ENTOCYCLE	GB
14	SOCIETA AGRICOLA ITALIAN CRICKET FARM SRL <a href="https://www.italiancricketfarm.com/">https://www.italiancricketfarm.com/</a>	ICF	IT

15	INVERTAPRO AS <a href="https://www.invertapro.com/">https://www.invertapro.com/</a>	INVERTAPRO	NOR
16	FIELD LAB ROBOTICS BV <a href="https://www.fieldlabrobotics.com/">https://www.fieldlabrobotics.com/</a>	FLR	NL
17	FoodScale Hub <a href="https://foodscaleshub.com/">https://foodscaleshub.com/</a>	FSH	RS
18	AgriFood Lithuania DIH <a href="https://www.agrifood.lt/">https://www.agrifood.lt/</a>	AFL	LT
19	CENTRO INTERNAZIONALE DI ALTISTUDI AGRONOMICI MEDITERRANEI <a href="http://www.iamb.it/">http://www.iamb.it/</a>	CIHEAM	IT

#### LEGAL NOTICE

The information and views set out in this application form are those of the author(s) and do not necessarily reflect the official opinion of the European Union. Neither the European Union institutions and bodies nor any person acting on their behalf may be held responsible for the use which may be made of the information contained therein.

# Table of Contents

Executive Summary.....	6
List of tables.....	7
List of figures.....	8
List of Abbreviations and Acronyms.....	10
Introduction.....	11
1.1 Scope of the Deliverable.....	11
1.2 Relation to Other Deliverables.....	11
1.3 Structure of the Deliverable.....	11
2. Legal and Economic aspects of insect rearing.....	12
2.1. Legal aspects.....	12
2.2. Economic aspects.....	13
2.3. Insects added value in food & feed.....	14
3. Technical Specifications for <i>Tenebrio Molitor</i> .....	15
3.1 Life cycle and physiology.....	15
3.2 Production requirements.....	17
3.3 Farming operations.....	18
4. Technical specifications for <i>Hermetia Illucens</i> .....	22
4.1 Life cycle and physiology.....	22
4.2 Production requirements.....	24
4.3 Farming operations.....	29
5. Technical specifications for <i>Acheta Domesticus</i> .....	33
5.1 Life cycle and physiology.....	33
5.2 Production requirements.....	36
5.3 Farming operations.....	38
6. Technical requirements and technology implementation.....	41
6.1. General systems and components.....	41
6.1.1 Climate control:	43
6.1.2. Sorting and harvesting:	45
6.1.3. Feed preparation and feeding.	48
6.2. Insect farm: Requirements of technical components.....	51
6.2.2. Human	52
6.2.3. Transport	52
6.2.4. Containers	52

6.2.5. Boxes	53
6.3. CoRoSect farm: Requirements of technical components .....	54
6.3.1. Human	54
6.3.2. Software	55
6.3.3. Cybercomponents	55
7. Conclusions .....	57
8. References .....	59

## Executive Summary

This deliverable contains the results of task T2.2 “Functional specifications” of the European Union (EU) HORIZON 2020 Programme (H2020) CoRoSect project, number 101016953. It is developed within the scope of WP2 which is responsible for the “Use-cases, user requirements and system architectures”.

The aim of this deliverable is to collect scientific information about insects rearing and the three different insect species (*Tenebrio molitor*, *Hermetia illucens* and *Acheta domesticus*) considered in the project in order to create a solid database for a better understanding about the functional specifications of the systems. The information in this deliverable, complemented with specific information and requirements from final users in the project, will set the starting point to define system architecture for CoRoSect system implementation in pilots definition.

The goal of this deliverable is to provide and establish which are the technical characteristics and boundaries for mechatronic solutions in the project.

All the information contained in this deliverable will be divided in two parts; the first one will be obtained from reviewing all the information available in literature related to legal and economic aspects, end-uses of edible insects and also the technical specifications for the targeted insect species. The second part of the information will be provided by insect farms in order to check all the detail required to take into account in an industrial rearing process and the differences among the above mentioned edible insects.

The present deliverable includes information of legal and economic introduction of insect rearing and technical specifications of the 3 insect species targeted. This information has been used to set the functional specifications of the CoRoSect system, including technical requirements and boundaries of the system.

## List of tables

Table 1. Nutritional value of the 4 most representative insect species .....	14
Table 2. Life cycle characteristics of <i>T. molitor</i> . .....	16
Table 3. Biological and life cycle parameters of <i>T. molitor</i> . .....	16
Table 4. Minimum, maximum, and optimal temperature (°C) conditions used on the rearing of eggs, larvae, pupae, and adults of mealworms. ....	17
Table 5. Minimum, maximum, and optimal relative humidity (%) conditions on the rearing of eggs, larvae, pupae, and adults of mealworms. ....	17
Table 6. Requirements to the life cycle of <i>T.molitor</i> . ....	17
Table 7. Key performance indicators for the BS area .....	19
Table 8. Key performance indicators for incubation and nursery area .....	19
Table 9. Key performance indicators of the fattening area. ....	21
Table 10. Risks to be considered in the different farm areas of <i>Tenebrio molitor</i> rearing process. ....	21
Table 11. Life cycle characteristics of <i>H.illucens</i> . ....	22
Table 12. Biological and life cycle parameters of <i>H.illucens</i> .....	24
Table 13. Minimum, maximum, and optimal temperature (°C) conditions used on the rearing of eggs, larvae, pupae, and adults of BSF. ....	24
Table 14. Minimum, maximum, and optimal relative humidity (%) conditions on the rearing of eggs, larvae, pupae, and adults of mealworms. ....	24
Table 15. Requirements to life cycle of <i>H.illucens</i> .....	26
Table 16. Key performance indicators for BS area. ....	29
Table 17. Key performance indicators for incubation and nursery area. ....	30
Table 18. Key performance indicators of the colony fattening area of BSF. ....	31
Table 19. Key performance indicators of fattening process area. ....	32
Table 20. Risks to be considered in the different farm areas of <i>Hermetia illucens</i> rearing process. ...	33
Table 21. Life cycle of <i>A.domesticus</i> . ....	33
Table 22. Developmental parameters for crickets raised at 30°C [40]. ....	34
Table 23. Minimum, maximum, and optimal temperature (°C) conditions used on the rearing of eggs and adults of crickets. ....	35
Table 24. Minimum, maximum, and optimal relative humidity (%) conditions on the rearing of eggs and adults of crickets. ....	35
Table 25. Average body weight of next to last and last instar and adult crickets at a rearing temperature of 30°C [40]. ....	35
Table 26. Requirements to life cycle of <i>A.domesticus</i> .....	36
Table 27. Key performance indicator of the BS area of crickets. ....	39
Table 28. Key performance indicator of the Incubation/hatchery area crickets. ....	39
Table 29. Key performance indicator of the fattening area of crickets. ....	41
Table 30. Risks to be considered in the BS and fattening areas of crickets. ....	41
Table 31. Components of an HVAC installation .....	43
Table 32. Control system, wiring and piping. ....	44
Table 33. Elements for transport. ....	46
Table 34. Sieving and packing machines. ....	47
Table 35. Feeding units. ....	48
Table 36. components for food preparation. ....	49
Table 37 Feed transport. ....	50
Table 38. Agents involved in an insect farm. ....	51
Table 39. CoRoSect agents .....	54



## List of figures

Figure 1. Adult stage of T.molitor .....	16
Figure 2. Larval stage of T.molitor .....	16
Figure 3. Pupa stage of T.molitor.....	16
Figure 4 Flowchart of T.molitor rearing process.....	18
Figure 5. Adult of H.illucens; Sexual dimorfism between males (M) and females (F) in H. illucens.....	23
Figure 6. Eggs of H.illucens.....	23
Figure 7.Larvae of H. illucens .....	23
Figure 8. Pupa of H.illucens.....	23
Figure 9. Flowchart of H.illucens rearing process.....	29
Figure 10. Adult stage of A.domesticus .....	34
Figure 11. Eggs stage of A.domesticus.....	34
Figure 12. Nymphs stage of A.domesticus.....	34
Figure 13. Flowchart of A.domesticus rearing process.....	38
Figure 14.General Process Flow-Chart In Insect Farming.....	42
Figure 15. Ventilation exhaust. ....	43
Figure 16. Grids and fans. ....	43
Figure 17. Enthalpic recuperator. ....	43
Figure 18. Humidifier. ....	43
Figure 19. Industrial chiller. ....	43
Figure 20. Probes. ....	44
Figure 21. Computer controller. ....	44
Figure 22. Insulation panels. ....	44
Figure 23. Air ducts. ....	44
Figure 24. Crate Dumper.....	46
Figure 25. Pneumatic conveyor. ....	46
Figure 26. Hopper. ....	46
Figure 27. Palletizer.....	46
Figure 28. Forklifts. ....	46
Figure 29. Sieving machine. ....	47
Figure 30. Packing machine. ....	47
Figure 31. Reception hopper. ....	48
Figure 32. Silo.....	48
Figure 33. Tank.....	48
Figure 34. Mixer. ....	49
Figure 35. Pre-Mixer. ....	49
Figure 36. Scales.....	49
Figure 37. Cooker. ....	49
Figure 38. Pumps.....	50
Figure 39. Diet dispenser. ....	50
Figure 40. Conveyor belt.....	50
Figure 41. Screw conveyor.....	50
Figure 42. Operator.....	51
Figure 43. Palletizer.....	51

Figure 44. Forklifts. ....	51
Figure 45. Water tank. ....	51
Figure 46. Feeders.....	51
Figure 47. Egg cups. ....	51
Figure 48. Cages.....	51
Figure 49. Tray. ....	51
Figure 50. Box. ....	51
Figure 51. Operator.....	54
Figure 52. PC with MES/IMS system. ....	54
Figure 53. Intelligent crates. ....	54
Figure 54. Manipulator robot. ....	54
Figure 55. Stacker robot.....	54
Figure 56. Automated guided vehicle.....	54
Figure 57. Camera. ....	54
Figure 58. Smart Industry Example (Digitization) .....	55

## List of Abbreviations and Acronyms

List of Abbreviations and Acronyms	
<b>AGV</b>	Automated Guided Vehicle
<b>BS</b>	Brood stock
<b>BSF</b>	Black soldier fly
<b>CAPEX</b>	Capital Expenditure
<b>D</b>	Deliverable
<b>d-cells</b>	Dynamic cells
<b>d-robot</b>	Destacking-stacking robot
<b>EFSA</b>	European Food Safety Agency
<b>ERP</b>	Enterprise Resource Planning
<b>FAO</b>	Food and Agriculture Organization
<b>FCR</b>	Feed conversion ratios
<b>HVAC</b>	Heating, Ventilating and Air Conditioning
<b>ICF</b>	Italian Cricket Farm
<b>I-crate</b>	Intelligent crate
<b>iFBOs</b>	Insect food bussiness operators
<b>IMS</b>	Information Management System
<b>IoT</b>	Internet of Things
<b>IPIFF</b>	International Platform of Insects for Food and Feed
<b>KPI</b>	Key Performance Indicator
<b>MES</b>	Manufacturing Execution System
<b>MOM</b>	Manufacturing Operating System
<b>m-robot</b>	Manipulation robot
<b>OPEX</b>	Operational Expenditures
<b>PID</b>	Proportional-Integral-Derivative (Controller)
<b>RAMI 4.0</b>	Reference Architectural Model Industry 4.0 (Industry 4.0)
<b>SCM</b>	Supply Chain Management
<b>T</b>	Task
<b>WP</b>	Work Package

# Introduction

## 1.1 Scope of the Deliverable

The scope of this deliverable is to provide a detailed description of the work performed in WP2 “Use-cases, user requirements and system architectures”, and specifically in Task 2.2: Functional Specifications.

Within this scope, this deliverable includes the technical specifications of the different species of insects in work environments, including information of life-cycles, production requirements and actual farming operations performed by end-users, which are involved in the CoRoSect project.

This information provides a valuable data-base of functional specifications to be considered in insect-rearing processes for the 3 main marketable insect species (*Tenebrio molitor*, *Hermetia illucens* and *Acheta domesticus*) considered in the project.

Functional specifications defined in the present deliverable will be used as a solid knowledge base for the development of system-architecture of CoRoSect system for later implementations and developments considered in the work programme.

## 1.2 Relation to Other Deliverables

The present deliverable is related to **Task 2.2. “Functional specifications”** included in WP2 “Use-cases, user requirements and system architectures”<sup>1</sup>. Deliverable 2.2. collects the information of the Technical Specifications of the different species of insects in working environments, setting the functional specifications required for proper definition of deliverable D.2.3. where the system architecture of CoRoSect components will be defined. It also has a slight link to Deliverable 4.1, where it will be helpful to understand the introduction of breeding processes in CoRoSect.

Later on the project, D2.2 is connected with WP3 “Biological, technical and economic aspects and parameters to insect rearing” where the scope is set on insect’s requirements; and with WP6 “Robotic actions planning and control”, WP7 “Cognitive robots and smart mechatronics” and WP10 “Pilot studies demonstration and evaluation”, where information from functional specifications will be used to design the technical components and verify that those components developed within the CoRoSect scope meets the technical requirements from final users.

## 1.3 Structure of the Deliverable

The deliverable is structured as follows: Section 2 provides an overview of the rules and regulations associated with insect production in general terms, as well as the economic aspects. It is highlighted the importance of the species selected for the project and its relevant industrial end-uses. Sections 3, 4, and 5 is a monographic description of every species developed under the CoRoSect project, namely *Tenebrio molitor* (Tenebrio), *Hermetia illucens* (BSF) and *Acheta domesticus* (Crickets) respectively. Every monographic section is subdivided in subsections specifically Part 1: Life cycle and Physiology, a description of the species from the bibliographical point of view; Part 2: Production requirements or end users’ technical information, where the information gathered from

the end user farm related to production stages is summarised; and Part 3: Farming operations, describing how the works and workflow are performed for every selected species. Section 6 is a description of the main equipment/elements required for insect farming and the kind of elements that should be incorporated to implement the CoRoSect farm. Section 7 presents the conclusion of the work carried out and Section 8 closes the document with the references.

## 2. Legal and Economic aspects of insect rearing

### 2.1. Legal aspects

Nowadays, edible insects are considered as a viable alternative for food security in a growing population. High nutritional values and the integration of insect rearing into new value chains in markets, considering circular-economy and bioeconomy concepts, presents insect rearing as a promising and sustainable source for both human food and animal feed.

Despite cultural barriers that may have slowed-down the implementation of insect farms around Europe, this emerging sector has recently broken some legal barriers to facilitate a proper development of the market.

In this sense, insects are included in the definition of novel food according to Regulation (EU) 2015/2283, in the category of "food from animals or their parts, which were not consumed by humans in the European Union before 15 May 1997". In addition, the European Food Safety Agency (EFSA) has produced a report assessing the risks associated with the production and consumption of insects for human consumption and identifies the need for further research in this area.

The list of insects that may currently be on the European market, because they are covered by the transitional measures laid down in Regulation (EU) 2015/2283 on Novel Foods and, depending on a decision on their inclusion or not, in the Union list (Implementing Regulation (EU) 2017/2470), are:

- *Acheta domesticus* (Orthoptera)
- *Tenebrio molitor* (Coleoptera)
- *Locusta migratoria* (Orthoptera)
- *Gryllobates sigillatus* (Orthoptera)
- *Schistocerca gregaria* (Orthoptera)
- *Alphitobius diaperinus* (Coleoptera)
- *Apis mellifera* (Hymenoptera)
- *Hermetia illucens* (Diptera)

Despite the diversity of commercially available insects, only a fraction of them are "easy to use" for rearing as food or feed. Recently, EFSA delivered an opinion on dried yellow mealworm (*T. molitor* larvae) as a novel food pursuant to Regulation (EU) 2015/2283. The novel food is referred to as the thermally dried yellow mealworm, either as whole dried insect or in the form of powder, being the main components: protein, fat and fibre (chitin). For that reason, EFSA considered that the consumption of *T. molitor* did not raise safety concerns and this is therefore the first comprehensive assessment of an insect-derived food product as a novel food.

Other regulations to which insect farming is subject include:

- Regulation (EC) No 1069/2009 on animal by-products. Insects are considered to be farmed animals for the production of food, feed or other purposes.

- Insect farming must comply with the general food hygiene and animal health requirements according to Reg (EC) No 178/2002 (General Food Law), No 852/2004 and No 183/2005 (Feed Hygiene).
- Invertebrates are excluded from Directive 98/58/EC: EU welfare rules do not apply to insects.
- Regulation (EU) No 2016/429 on transmissible animal diseases.
- Regulation (EU) No 1143/2014 on the prevention and management of the introduction and spread of invasive alien species.

## 2.2. Economic aspects

Insect rearing could be accepted as part of the solution to the global demand for primary foodstuffs, providing, in addition, an interesting way of circular economy applied to the agri-food industry. Also, several insect species exhibit the capability of converting efficiently organic wastes and by-products of agricultural processes to animal proteins. This bio-conversion process is a valid alternative to more traditional and conventional methods to treat organic waste [1].

On the other hand, insect farming for human food and as feedstock for livestock and fish could contribute to food security considering the low emissions of greenhouse gases, and high Feed Conversion Ratios (FCR) [2].

FCR is a measure of the efficiency of an animal to convert mass of feed into greater body mass (kg feed / kg live weight), the FCR of cricket is about 1.7, which is lower than the value of pork (FCR of 5.0) and even lower than the FCR of beef (10.0). Insects such as *H. illucens* are able to transform food waste into high quality food rich in fat and protein. According to one study, these species could collectively convert 1.3 billion tonnes of bio-waste per year [3].

Related to commercial farming, insect life cycle characteristics such as dependence on temperature and photoperiod and other environmental conditions are key in the success of the rearing process. For that reason, the easiest insects to rear are relatively small, multivoltine (more than one generation per year), plant-feeding insects with no unusual environmental requirements. In general, species that infest common crops, landscape plants or stored products are particularly suitable for artificial rearing such as beetles (*Coleoptera*), flies (*Diptera*) and grasshoppers (*Orthoptera*).

According to the International Platform of Insects for Food and Feed (IPIFF) [4], insect farming is a growing industry in Europe. In 2019, the European iFBOs (insect food business operators) accounted for about 500 tonnes of insect-based products (whole insects, insect ingredients and products incorporated with edible insects) placed on the European market. The market for edible insect-based food products is projected to grow rapidly in the next few years and is forecasted to produce about 260,000 tonnes by 2030. Considering insect species covered by iFBOs in the survey conducted by IPIFF in 2020, main species in European market are black soldier fly (*Hermetia illucens*); yellow mealworm (*Tenebrio molitor*); lesser mealworm (*Alphitobius diaperinus*); house cricket (*Acheta domestica*); banded cricket (*Gryllodes sigillatus*); migratory locust (*Locusta migratoria*).

In the scope of the CoRoSect project, will be set for 3 of the most promising species for market development in the coming years: *Tenebrio molitor*, *Hermetia illucens* and *Acheta domestica*.

## 2.3. Insects added value in food & feed

Many insects are reared for insecticide trials, entomological research and population restoration. Some notable economic examples are silkworms and honeybees, while many pest and predatory insects are bred for biological control or agricultural trials. Also, the rearing of insects not only are focused on using like pet food, but also there are other applications closely related to their high protein content.

The nutritional value of edible insects is widely recognised. Table 1, shows a summary of the nutritional content of main species farmed.

Table 1. Nutritional value of the 4 most representative insect species

Order	Insect	Protein (%)	Fat (%)	Zn (mg/100 g)	Fe (mg/100 g)	Mn (mg/100 g)
Diptera	<i>H. illucens</i>	30,4	11,6	4,3	10,1	6,4
Coleoptera	<i>T. molitor</i>	61,9	19,6	5,0	12,7	3,8
Coleoptera	<i>Z. morio</i>	54,8	33,0	7,2	3,8	2,0
Orthoptera	<i>A. domesticus</i>	42,0	23,6	12,8	11,2	4,1

Recent studies have demonstrated their potential as a protein base for bioactive peptides with applicability in the food industry and agriculture:

- *A.domesticus* produces bioactive peptides capable of being part of functional ingredients in food preparations and nutraceuticals [5].
- The protein hydrolysate of *H.illucens* contains a large amount of essential amino acids, especially lysine (8.0%), leucine (7.7%) and valine (7.3%) of great interest for the formulation of biofertilisers [6].
- *H.illucens* produces antimicrobial peptides such as defensin-4 and cecropin that can be used for the formulation of new biocides as growth inhibitors of pathogenic microorganisms[7].
- Protein hydrolysates from insects such as *Z.morio* can be used for the development of new biostimulants based on peptides with antioxidant activity [8].

As mentioned above, another aspect to be taken into account during insect rearing is the high feed conversion ratio (FCR) and the low environmental impact they cause. Several research studies have concluded that *Hermetia* larvae can successfully bioconvert different low-value organic materials into larval biomass with high protein and lipid content that can be used as animal feed and in aquaculture. On the other hand, protein production from *Hermetia* larvae has been shown to have a lower environmental impact than conventional protein sources (fishmeal), making it a promising source of sustainable protein [9,10].

Lipids obtained by insect farming also open up interesting possibilities for food and industrial purposes, such as the production of biodiesel, and for the agricultural industry with the application of biocides based on antimicrobial lipids. Among them, lauric acid and its monoacylglycerol derivative, glycerol monolaurate, show the highest antimicrobial activity, with larvae of *H. illucens* and adults of *A. domesticus* representing the main sources of lauric acid with more than 40% of lauric acid [11].

In general, insects, especially during the larval stage, contain high proportions of fat that are highly dependent on their diet and developmental stage. It should be noted that both *Z. morio* and *H. illucens* could be selected as the best candidates for biodiesel production due to their high content of saturated fatty acids. On the other hand, the profile of *T. molitor* shows a high content of oleic acid (13.4%), which has modulatory effects on a wide range of physiological functions, having anti-inflammatory properties.

On the other hand, another use of insect rearing is the production of chitosan. The exoskeleton of insects is structurally composed of chitin, a nitrogen-containing polysaccharide found, for example, in the cuticle of *Hermetia* larvae. After a deacetylation process, chitin is transformed into chitosan. This polymer has many applications and is commonly used in water purification and wastewater treatment. Actually, it is being used in other industrial sectors, from agriculture to pharmaceuticals, cosmetics and textiles [12].

In conclusion, due to the sustainability of its rearing, mass cultures of insects seem to be economically viable.

### 3. Technical Specifications for *Tenebrio Molitor*

*Tenebrio* is one of the most importantly reared insect species in Europe. It was originally reared as live feed for reptiles and pet birds. Herpetology aficionados were among the first to rear *Tenebrio* larvae, mainly serving as their personal live feed stock, whilst zoo and universities developed rearing techniques as well to maintain their own animals. In time, more and more commercial breeders appeared, using a more technical approach to its rearing. *Tenebrio* started to be introduced for human consumption around a decade ago. After several legislative changes, *Tenebrio* has become one of the insect species approved for production for human consumption, allowing opportunities for commercial exploitation. Since FAO published the “Edible insects - Future prospects for food and feed security”, the idea of rearing insects for food and feed is a growing tendency.

This section is a compilation of information regarding the rearing of *Tenebrio*, including work dynamics, limitations affecting production, and proposed technical solutions for the industrialization of the insect under the CoRoSect Project.

To start, this section begins with a description of the life cycle and physiology of *Tenebrio*, with references to current research. Moving on to subsection 2, it shows **information gathered during the execution of Task 2.1 from the end user INVERTAPRO** as representative of the rearing of *Tenebrio* in the CoRoSect Project. Finally, subsection 3 describes the work chain that will be carried out in the *Tenebrio* insect farm.



#### 3.1 Life cycle and physiology.

*Tenebrio* is considered as a storage pest and usually appears in places where grains, cereals, and flour are stored, thus commonly known as mealworm. One of the reasons for its popularity is the ease in rearing, being easily replicated on an industrial scale with high growth rates and life cycles that last longer than other species. It has good nutritional values for both humans and for animals.

This section covers the morphological description of *Tenebrio* in different states of development, accompanied by images that will aid in its identification, as well identifying certain factors such as temperature, humidity and light and how they affect the rearing of the species. Life cycle of *T. molitor* is constituted by the stages described in Table 2.



Table 2. Life cycle characteristics of *T. molitor*.

STAGE	IMAGE
<p><b>Adult:</b> The adults are generally 1.2 to 1.89 cm in length. This stage can last from 16 days to 173 days [13]. Adult females are generally receptive throughout their adult lives (up to 2 months) copulating with only a single male, regardless of her access to a mate. Increase in fecundity is increased by mating more than once [14]. An adult female can produce 250 to 1000 eggs. Eggs laid by mated females have a 90% hatch rate [15].</p>	 <p>Figure 1. Adult stage of <i>T. molitor</i></p>
<p><b>Egg:</b> Eggs can be found attached to the substrate or the walls or floors of the containers, either single or in clusters. Temperature plays an important part in egg hatching. Eggs at a temperature of 26-31 °C hatch on day 4 or day 5 at 35°C, while at eggs incubated at 15 °C hatch on day 35 [16,17]. On the average eggs hatch between 7 to 15 days [18, 19]. Optimal temperature for egg hatching is at 25–27°C. It has been demonstrated that temperatures below 17°C inhibit embryonic development while temperatures above 30°C will increase the death rate [20].</p>	
<p><b>Larvae:</b> The larval stage can range from 110.8 at 30°C to 244 at 17°C. The number of larval instars varies from 11 to 20 [21]. Recent studies show that the larvae length can range between 20mm to 31 mm, while average body mass ranges between 126 mg to 220 mgs [22,23]. Temperature combined with RH affects both the number and the length of the instars and influences the water absorption capacity of the different stages of the life cycle. The optimum temperature range used for rearing larvae is at 27–28°C [24]. Morales-Ramos et al. [23] studied the effect of density on adult population survival and production, obtaining an optimal density of 8.4 adults/dm<sup>2</sup> for mass production purposes.</p>	 <p>Figure 2. Larval stage of <i>T. molitor</i></p>
<p><b>Pupal:</b> Pupal stage has a range of 6 days at 27°C to 20 days. Optimal temperature range for rearing pupae is at 27–33 °C [23-25].</p>	 <p>Figure 3. Pupa stage of <i>T. molitor</i></p>

Depending on the different stages of *Tenebrio*, it is essential to take into account diverse parameters such as size, body mass, temperature, etc. The following tables show briefly the different parameters and its optimal ranges for the biological life cycle of *T. molitor*.

Table 3. Biological and life cycle parameters of *T. molitor*.

Biological and life cycle parameters			
	Minimum	Average	Maximum
No. of Eggs	250	250 - 500	500 - 1000
Length (mm)			
Larvae	20 - 28	28	25-32
Adult	12 - 15.5	-	16
Body mass (mg)			
Larvae	130	120 - 220	134 - 220
Adult	-	136	-
Duration (days)			

<b>Complete Life Span</b>	75 - 280	80 - 294	90 - 630
<b>Egg Stage</b>	4 - 10	7 - 15	10 - 34 (at 15°C)
<b>Larval Stage</b>	110.8 - 180	203.3 - 241.9	216 - 540
<b>Pupa Stage</b>	6 - 6.51	5 - 9	18 -20
<b>Adult Stage</b>	16 - 37	31.8 - 62.05	60 -173

Table 4. Minimum, maximum, and optimal temperature (°C) conditions used on the rearing of eggs, larvae, pupae, and adults of mealworms.

<b>Temperature (°C)</b>			
	<b>Minimum</b>	<b>Average</b>	<b>Maximum</b>
<b>Eggs</b>	15-17	25-27	35
<b>Larvae</b>	17	27-28	30
<b>Pupae</b>	21	27.5-28	35
<b>Adult</b>	10	25	35

Table 5. Minimum, maximum, and optimal relative humidity (%) conditions on the rearing of eggs, larvae, pupae, and adults of mealworms.

<b>Relative Humidity (%)</b>			
	<b>Minimum</b>	<b>Average</b>	<b>Maximum</b>
<b>Eggs</b>	12	60-75	98
<b>Larvae</b>	12-30	60-70	98
<b>Pupae</b>	12	70-75	98
<b>Adult</b>	12-20	90-100	98

### 3.2 Production requirements.

Tenebrio farms are distinct in terms of their rearing process and no two farms are ever the same. Every farm has its own process concerning the breeding techniques and development. This section shows which operations are done in each stage of development in the rearing process and the corresponding requirements based on the **recorded information from INVERTAPRO** during the accomplishment of Task 2.1. Tables are provided for ease of information retrieval for CoRoSect technological partner.

Table 6. Requirements to the life cycle of *T.molitor*.

1.CALCULATE DENSITY	2.CALCULATE AVERAGE INDIVIDUAL SIZE/WEIGHT	3.COUNT NUMBER OF INDIVIDUALS	4.IDENTIFY FEEDING NEEDS	5.MONITOR AND IDENTIFY ABNORMALITIES	6.COLLECT SAMPLES	7.SCAN FOR MOVEMENT
<b>THE LIFE-CYCLE INSTAR</b>						
Larvae	Larvae, pupae, adults	Eggs, larvae, pupae, adults		Larvae		Adults
<b>ABIOTIC CONDITIONS (TA   HUMIDITY   CO2   PHOTOPERIOD L:D)</b>						
[Incubation & Nursery Area] 32 °C   85%   10:14 [Fattening Area] 30 °C   70%   10:14	[Incubation & Nursery Area] 32 °C   85%   10:14 [Fattening Area] 30 °C   70%   10:14 [Broodstock Area] 30 °C   75%   10:14	[Incubation & Nursery Area] 32 °C   85%   10:14 [Fattening Area] 30 °C   70%   10:14 [Broodstock Area] 30 °C   75%   10:14	[Incubation & Nursery Area] 32 °C   85%   10:14 [Fattening Area] 30 °C   70%   10:14	[Incubation & Nursery Area] 32 °C   85%   10:14 [Fattening Area] 30 °C   70%   10:14	[Incubation & Nursery Area] 32 °C   85%   10:14 [Fattening Area] 30 °C   70%   10:14	[Broodstock Area] 30 °C   75%   10:14
<b>SIZE OF INSECT AT THE GIVEN LIFE CYCLE STAGE</b>						
Larvae: 1 - 35 mm	Larvae: 1 - 35 mm Pupae: ~15 mm Adults: ~15 mm	Eggs: ~0.1 – 0.5 mm Larvae: 1 - 35 mm Pupae: ~15 mm Adults: ~15 mm		Larvae: 1 - 35 mm		Adults: ~15 mm
<b>PARAMETERS MONITORED</b>						
- Ratio/weight (biomass) estimation of insect - Compost & feed.	- Size of insects		- Amount of feed present (if any). - Moisture content.	- Presence of abnormalities (pathogens, parasitoids, problems, junks, etc.).		- Count number percentage of non-moving beetles.
<b>TASK PROPERTIES AND METRICS, FOR QUALITY CONTROL AND AUTOMATION PURPOSE</b>						
- Automatic sampling and measurement by artificial vision for density, size and quantity estimation.  - Separation of compost fraction.			- Physical state of the substrate: a small agitation of the contents of the container (shaking the container, or introducing a tool), gives us information of: 1. Whether the substrate presents fermentation problems 2. If the substrate is too "pasty" (and hinders the activity of the larvae) 3. If it has a suitable colour (a darker colour usually means that it is being properly digested) 4. If it presents pathogens colonising the substrate or the food (fungal colonies are discovered through the mycelia they develop). 5. Identify another abnormalities		- Automatic sampling.  - Separation of compost fraction.	- Establishment of activity ratios at the surface and in the substrate. - Collection of thermal information of the larvae, and their distinction from the substrate or food mass. - Small agitation of the substrate to collect information not visible

	<p>- Taking thermal photographs to check the temperature distribution within the substrate, and to correlate this data with the temperature collected by the temperature sensor in the crate, and the temperature sensor in the room.</p>		<p>on the surface.</p>
<b>SAMPLING RATE FOR AUTOMATION PURPOSE</b>			
Daily			

### 3.3 Farming operations.

This part describes, in a more detailed form, the work done in the various farm sections or areas. The farm is divided in four areas:

1. The reproduction or **brood stock** is where the adults are allowed to maturation until such a time that they can produce eggs.
2. **Incubation and hatchery** are the area where the eggs are kept until the appearance of larvae.
3. **Fattening** is where small larvae are kept until the desired size is attained.
4. Finally, the **harvesting area**, where the insects are separated from substrate and cleaned before the processing

Operations that need to be done in each area are specified here, including Key Performance and Risk Indicators. If the actual operation is substituted for an automated one by CoRoSect, it will then be possible to calculate the best option with respect to what has been previously utilized.

The descriptions of the operations with regards to each area are shown in the following figure (Figure 4):

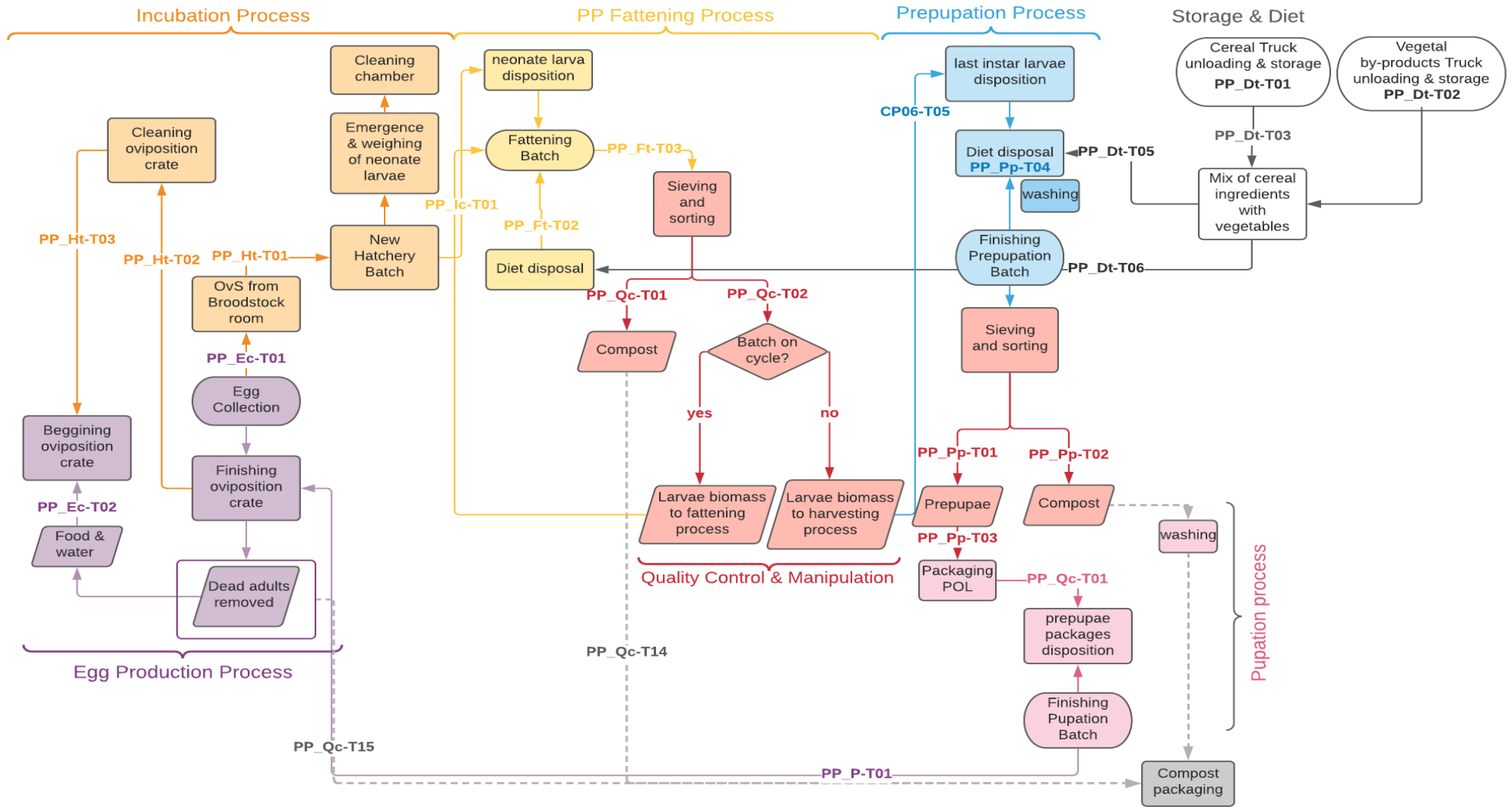

Figure 4 Flowchart of *T.molitor* rearing process

The separate units which are involved in the target insect farming are described below:

- 1) **Brood stock (BS):** It is the unit where eggs are produced by the adults and the following tasks are executed.
  - a) **Brood stock replacement:** Adults 1,25 - 1,8 cm length will be placed in oviposition devices. Those which are too old with less than adequate oviposition will be culled. The used devices will then be put in a container and transported to waste segregation where the devices will be washed and reused, while frass substrate and individuals will be thrown away. New brood stock is chosen when adults emerge from the pupa cages, after which they are grouped in a new oviposition device containing food/oviposition substrate (either wheat bran, wheat flour or any other cereal substrate) and a source of water, and vitamins such as carrots or apple pieces. The oviposition devices are located in the brood stock rooms.
  - b) **Egg collection:** Adults are separated weekly from the oviposition substrate (containing freshly released eggs) and relocated in a new oviposition substrate. The eggs measure about 1 mm in size.
  - c) **Feeding:** Adults are fed with a dry source of feed (normally cereal derivatives) and supplemented with water and vitamins in the form of shredded vegetables such as carrots, apples, or a mix of vegetables. Since the dry source of feed acts as an oviposition substrate, and it is replenished daily, it does not need to be considered in the feeding. However, to keep the individuals in a good condition, the moisture source is renewed periodically, removing dry or deteriorated pieces with fresh ones.
  - d) **Revision:** Ovipositing devices are inspected daily. Signs of pest, diseases or other hazards are marked or eliminated if needed. Checks for density, unusual mortality, substrate degradation with fungi or too wet spots, pests in the form of mites or foreign insects will also be done.
  - e) **Cleaning and maintenance:** The cleaning should be done weekly for the entire room and adult cages have to be cleaned when adults are culled, and before the new adults batch is inserted.

Table 7 shows the KPI of the area and Table 10 the risks for the BS area of Tenebrio and the rest of the following areas.

Table 7. Key performance indicators for the BS area

Key performance indicator	Value	Deviation
Adult sex ratio	M:F   50:50	Review of the pupation process. Review of batch traceability.
Percentage of adult emergence	> 91%	Review of the pupation process. Review of batch traceability. Review of the cage conditions. Review of abiotic conditions.
Female fecundity	> 88%	Review of the pupation process. Review of batch traceability. Review of the cage conditions.
Mortality presence	Non-quantitative: presence of abrupt death	Review of batch traceability. Review of the cage conditions. Review of abiotic conditions. Review of the water supply. Review of disinfectants used.

2) **Incubation and nursery:** The unit concerns the incubation of eggs and the development of small larvae until such a stage that larvae can be sent to the fattening unit.

- a) **Incubation:** Incubating boxes from the brood stock containing the ovipositing substrate with the eggs are placed inside the incubation unit for eggs to hatch.
- b) **Feeding:** When eggs start to hatch and the first stage larvae emerge, some pieces of moisture substrate are added as water and feeding source for the small larvae. Deteriorated pieces of wet feed are removed as well as any detrimental substrate.
- c) **Revision:** Daily revision for presence of pest or diseases which could affect the life of the little larvae are carried out. Boxes with abnormalities are marked for the following, corrected, or eliminated if necessary.

Table 8 indicates the KPI for the nursery area of Tenebrio.

Table 8. Key performance indicators for incubation and nursery area

Key performance indicator	Value	Deviation
Egg hatch ratio	> 84%	Review of the hatchery process. Review of batch traceability. Review of the brood stock and hatchery room conditions.
Mortality ratio	< 14%	Review of the incidents and observations of the batch. Review of abiotic conditions. Review of diet batches.
Sieving performance	> 98%	Larval assessment: detection of heterogeneity problems. Review of feeding batches. Review of abiotic conditions. Review of sieving equipment and its maintenance plan.



**3) Fattening:** This unit concerns the growth of the larvae from small development state to harvesting size.

**a) Feeding:** Upon entering the fattening unit, they are fed weekly, and to achieve the task, pallets with the crates are moved to the feeding room where food is replenished with new diet. The diet is composed of a mixture of vegetable silage and grain mix to an approximate water content of 60% and shredded to a size of <10 mm particle size. Diet is placed on top of the substrate, layering it in such a way that it will not be too thick to suffocate the larvae nor too thin that the larvae may consume the feed rapidly. A robot arm will have two trays under the feeding point, and it will receive 175 grams of diet in each tray. Each tray will have a population density of 20,000 individuals per 2,400 cm<sup>2</sup>. The diet should be well distributed, since larvae are not inclined to move towards the food, which however may lead to uneven growth of some larvae. When the feeding has been concluded, the crates are piled back into the pallet and when the pallet is filled up with crates, it will be brought back to the fattening unit.

**b) Waste removal and larvae sorting:** Weekly, the uneaten feed plus the frass of the larvae, will build up inside the crates, extra-loading the organic matter and occupying space, as well as increasing the probability of undesirable events (mortality, diseases or pest outbreaks). To eliminate the waste, the content of the crate will be sieved. To do that, the pallets with the crates will be moved to the sieving device. Crates are then destocked and set upside down over the hopper of the sieve, emptying the content of the recipient. The material is then sieved, separating thin particles (frass, dust, and small uneatings), larvae, and larger chunks in different fractions. Furthermore, with adequate sieving, different larvae sizes can be separated and restocked in crates containing larvae of similar size. Frass and chunks are then set as compost. The new crates are stacked on the pallet which will then be relocated to the fattening unit.

**c) Counting of individuals:** As a necessity for feeding adjustment, larvae population is estimated visually to deduce the number of larvae as well as their developmental stage, moreover, to estimate how much feed is needed in subsequent feedings. Too high larvae density will produce development delays and will need more food. Too low larvae density will use the space and feeding becomes less efficient. The crates are checked before feeding. A size of 20.000 larvae per crate is desirable.

**4) Harvesting:** (After 8 weeks of fattening) This is done when larvae have reached target size. The pallets with the crates are brought to the sorting sieve. There the boxes are emptied over the sieving hopper, then sieved in the machine and the contents of which will be divided depending on larvae size and frass. Frass is disposed, and it is considered as one of the outputs. Larvae at the targeted size are stocked in boxes for processing, while larvae of other sizes are stocked in crates and sent to the feeding unit to return to the system.

**a) Quality control:** The crates which are selected for quality control are brought to the quality control area where larvae are counted, weighed, dry weight estimated, and dead individuals counted. The results are saved as a basis for decision making.

**b) Pupa:** Larvae sufficiently large enough to be transformed to pupae are set in the fattening room and fed with shredded vegetables until the first pupae appear. Then,

pallets with the crates are brought to the sorting room where pupae are separated from larvae and substrate. Larvae with substrate are sent back to the crates, fed, and placed back in the fattening unit. Pupae are then relocated in pupae cages and kept in the pupation area until adults start to emerge. Adults are then brought to the adult area.

Table 9 are the KPI and Table 10 the risks of the fattening area of Tenebrio.

*Table 9. Key performance indicators of the fattening area.*

Key performance indicator	Value	Deviation
Larva individual weight (larva harvested)	According to the diet used	Review of the density on the batch. Review of feed batches. Review of abiotic conditions. Presence of substrate problems. Traceability of the batch.
Larva total biomass	Value specified according to batch size	Review of mortality in the batch. Review of feeding batches. Review of abiotic conditions. Presence of substrate problems. Traceability of the batch. Review of sieving equipment.
Mortality ratio	< 17%	Review of the state of the substrate. Review of feed batches. Start of the procedure to identify pests and diseases.
FCR	According to the diet used	Review of the state of the substrate. Review of feed batches. Traceability of the batch.
Feeding ratio	According to the diet used	Review of the state of the substrate. Review of feed batches. Traceability of the batch.

*Table 10. Risks to be considered in the different farm areas of Tenebrio molitor rearing process.*

Risk	Value	Corrective action
Pests	Presence	Initiation of source location and eradication procedure. Differentiation according to rodents, parasites or diseases.
Toxics	Presence	Cleaning procedures. Evacuation or transfer procedures. Input replacement procedures.
Food contamination	Presencia	Initiation of the traceability study. Pesticide Analysis.

## 4. Technical specifications for *Hermetia Illucens*

BSF is possibly the most relevant insect species from an industrial point of view. Of this species, the most relevant stage are the larvae which have the capability to grow at a high rate and feeding on a wide variety of organic matter. BSF larvae breeding was not known in Europe until the beginning of the second decade of this century. It was then that its grand potential to be industrialized was realized with the flourishing of various projects dedicated to its industrial exploitation. BSF is mainly reared for protein production fed with other organic sub-products which have little market value. Fats and proteins are currently used in agriculture and pet food at the moment, although they will be utilized as feed for poultry and swine soon.

As indicated in the previous section, here is a compilation of relevant information that can be utilized later on in the CoRoSect project.

The primary part is a description of the life cycle, followed by an explanation of the breeding and the necessary requirements associated with each stage of development based on **information from the end users involved in the production of the species (NASEKOMO, ENTOCYCLE and ENTOMOTECH)**, and finally a description of work for each area.

### 4.1 Life cycle and physiology.

*H. illucens* is an insect belonging to the order of the dipterans. *BSF* (Figure 5) is commonly known as "soldier fly" (Black Soldier Fly) and belongs to the Stratiomyidae family. This species is possibly native to America but because of anthropic activity it has been distributed throughout all the humid and subtropical regions of the planet [26]. In Europe this species was first recorded in Malta in 1926, and since then it has been cited in other countries of the Mediterranean area, such as Albania, Croatia, France, Italy, southern Switzerland, Portugal and Spain. In the Iberian Peninsula, *H. illucens* was registered for the first time in 1954 in Spain, and in Portugal in 1995 [27].

BSF are not considered as a plague-causing species. Not one of its stages of development causes economic devastation nor environmental harm. The offspring are easy to provide with the necessary requirements for each stage of development. The larvae are the most exploited stage, which can develop at such a rate that the cycle from egg to egg can be done in a month's time. The species also allows the use of a great population density resulting in a very intensive production.

Stages description for BSF is shown in Table 11:

Table 11. Life cycle characteristics of *H.illucens*.

STAGE	IMAGE
<p><b>Adult:</b> The adult BSF is 15-20 mm, does not need to feed, surviving on the large storage of body fat (Diclaro and Kaufman, 2009). Adults have predominantly dark pigmentation, with brown or black wings. The size of the antennas is at least twice the length of the head, and they consist of eight irregular artefacts, the last of which is flagelomer, and has an edge. The legs are mainly black, although in the basal area of all tarsi a white pigmentation is observed.</p>	

The female usually is larger than the male, although there is no obvious sexual dimorphism with the naked eye. The genital structure represents the only character of sexual dimorphism of this species. Male genitalia are relatively short, and have two pairs of lateral posterior lobes, a pair of fences and a pair of exceedingly small gonostils. The sexual organ complex is very thin and dilated in its basal part [28]. Female genitalia is composed of a pair of long fences formed by two segments; it has a long subgenital plaque in its distal part pointedly and a subtriangular genital furca. Adults begin intercourse about 5 days after the emergency, and it takes place during the flight.

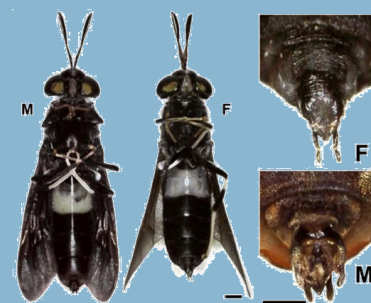

Figure 5. Adult of *H.illucens*; Sexual dimorfism between males (M) and females (F) in *H. illucens*

**Egg:** After mating the females lay around 600 eggs (united in a cluster) in cracks or crevices near decomposing organic matter. Each oval-shaped egg measures approximately 1 mm in length, with a coloration that varies from white to pale yellow or cream. First stage larvae emerge in four days at 24 °C [29].



Figure 6. Egss of *H.illucens*

**Larvae:** The larvae of this species have an essentially elongated shape (0.85 to 30 mm) with a tapered anterior end, and a rounded posterior. The tegument is whitish to darker, and strongly sclerotized according to age. They have a characteristic quetotaxia both in their ventral and dorsal parts. They weigh up to 220mg, reaching up to 27mm in length and 6 mm in width [30]. Larvae can develop in a wide diversity of organic matter, from manure and decomposing meat, sludges to fruits and vegetables [31]. Once they emerge, the larvae begin to feed on organic matter, reaching an average reduction of 55% [32]. Due to the high densities in which they develop, and the voracious appetite of the larva, fresh organic matter is processed extremely quickly, further suppressing bacterial growth or retaining it. In this way the bad smell due to the decomposition by the action of the microorganisms is minimized. This feeding activity is also capable of repelling the oviposition of housefly females [33].



Figure 7. Larvae of *H. illucens*

**Pupa:** They form a black and immobile pupa after crossing 6 larval stages. Prepupae empty their GIT track, stop feeding, and migrate out of the waste substrate [34].



Figure 8. Pupa of *H.illucens*

The duration of each stage of the life cycle of *H. illucens* is influenced by various abiotic and biotic factors, which can significantly alter the development of the preimaginal stages of this species.<sup>28</sup> The

optimum temperatures for the biological cycle of *H. illucens* are in the range 24 to 29.3 °C. Ambient humidity can have important physiological effects affecting the development, longevity and oviposition of *H. illucens*. The optimum range for the development of the species is 50 to 99% relative humidity [35].

The following tables (Table 12, Table 13 and Table 14) show briefly the different parameters and its optimal ranges for biological and life cycle of BSF.

*Table 12. Biological and life cycle parameters of H.illucens*

	Minimum	Average	Maximum
<b>No. of Eggs</b>	546	998	1,505
<b>Egg mass</b>	15.8	29.1	40.6
<b>Length (mm)</b>			
<b>Larvae</b>	17.3	18.78	19.35
<b>Adult</b>	9.19	13.34	16.46
<b>Body mass (mg)</b>			
<b>Larvae</b>	134.5	178.4	316.7
<b>Adult</b>	20	34	51
<b>Duration (days)</b>			
<b>Complete Life Span</b>			
<b>Egg Stage</b>	1.9	2.1	4.2
<b>Larval Stage</b>	21	28	87
<b>Pupa Stage</b>	7	8	19
<b>Adult Stage</b>	3	7	9

*Table 13. Minimum, maximum, and optimal temperature (°C) conditions used on the rearing of eggs, larvae, pupae, and adults of BSF.*

<b>Temperature (°C)</b>			
	Minimum	Average	Maximum
<b>Eggs</b>	15	30 – 35	40
<b>Larvae</b>	15	27 - 28	30
<b>Prepupae</b>	15	30 – 35	37
<b>Pupae</b>	15	30	35
<b>Adult</b>	11	25 – 30	35

*Table 14. Minimum, maximum, and optimal relative humidity (%) conditions on the rearing of eggs, larvae, pupae, and adults of mealworms.*

<b>Relative Humidity (%)</b>			
	Minimum	Average	Maximum
<b>Eggs</b>	67	75-85	95
<b>Larvae</b>	43	60-70	95
<b>Pupae</b>	62	70-75	81
<b>Adult</b>	65	75-85	90

## 4.2 Production requirements

Black soldier fly farms are diverse, thus all the information and contributions from the previously mentioned end users rearing BSF are compiled here, and here and in the following Table 15

Table 15. Requirements to life cycle of *H.illucens*

1.CHECKING THE STATUS OF THE ADULT CAGES	2.CHECKING THE CONDITION OF EGGS	3.CHECKING THE STATUS OF THE CRATE'S CONTENT: LARVAE STATUS	4.CHECKING THE STATUS OF THE CRATE'S CONTENT: LARVAE STATUS	5.CHECKING THE STATUS OF THE CRATE'S CONTENT: LARVAE STATUS	6.CHECKING THE STATUS OF THE CRATE'S CONTENT: SUBSTRATE STATUS	7.QUALITY CONTROL TASKS
<b>THE LIFE-CYCLE INSTAR</b>						
Adults	Eggs	Larvae: 0 - 5 DOL	Larvae: 5 - 15 DOL	Larvae: prepupae	Substate	Larvae, prepupae, pupae, adults
<b>ABIOTIC CONDITIONS (TA   HUMIDITY   CO2   PHOTOPERIOD L:D)</b>						
[Broodstock Area] 30 °C   85%   900 ppm   12:12	[Nursery Area] 28 °C   80%   900 ppm   no	[Incubation Area] 28 °C   85%   900 ppm   no	[Broodstock fattening Area] 29 °C   70%   1200 ppm   no [Fattening Area] 30 °C   70%   1600 ppm   no	[Fattening Area] 30 °C   70%   1600 ppm   no	[Incubation Area] <35 °C   70% [Broodstock fattening] <42 °C   70% [Fattening Area] <45 °C   70%	29 °C   70%   1200 ppm   no
<b>SIZE OF INSECT AT THE GIVEN LIFE CYCLE STAGE</b>						
15 - 30 mm	~1 mm length, 0.15 mm width	1-10 mm length	10 - 30 mm	20 – 25 mm	-	-
<b>PARAMETERS MONITORED</b>						
Sex rate, weight, activity, general state of the cage	Oviposition substrate weight, number of clusters	Size, colour, movement capacity			Texture, colour, weight, presence of problems	size, number, weight and colour of individuals; presence of pathogens and parasites
<b>TASK PROPERTIES AND METRICS, FOR QUALITY CONTROL AND AUTOMATION PURPOSE</b>						
The aim is to measure the activity of the adults, as well as the condition of the cages containing them:  - Adult activity: 1. Estimate, if possible, the number of adults occupying a specific volume of the cage, in order to establish a percentage of pupae emergence. 2. Estimation of	Automatic collection of oviposition substrates (OS), as they are collected from the cages. As the OS are identified, we can know their weight before and after they are placed in the cages. We can also  - Take images of the OS when they are removed, so that we can correlate the weight of the clusters with the number of clusters.	This task can be carried out at the same time as the inspection of the crates' substrate.  - Larval size and activity: routine checks of larval size and activity (movement & velocity) can be carried out routinely.  - Exoskeleton quality assessment	This task can be carried out at the same time as the inspection of the crates' substrate.  - Larval size and activity: routine checks of larval size and activity (movement & velocity) can be carried out routinely.  - Exoskeleton quality assessment	This task can be carried out at the same time as the inspection of the crates' substrate.  - Larval size and activity: routine checks of larval size and activity (movement & velocity) can be carried out routinely.  - Exoskeleton quality assessment	In general, it is necessary to check the condition of the crates every few hours. Combined with vibration and sound sensors, visual monitoring of the crates is very important. Mainly:  - Substrate height: this would indicate the amount of digested feed.  - Physical state of the substrate: a small	The tasks are simple and can be done on a static device (such as a tray), or on a mobile device (automatic counting and weighing): collection of the weight, number and shape of individuals, as well as recognition of their mobility and the presence of parasites, diseases or other problems in the

<p>females ovipositing on the substrates and oviposition.</p> <p>3. Sexing of adults: this is a complicated task. Normally, a sample of <i>Hermetia</i> pupae is taken to the laboratory, and the emerging adults are manually sexed. In this way an estimate can be made of the sex of the adults emerging in the cage (the sex ratio is essential to obtain adequate fertility in the process). Sexing in the cage would be achieved by observing the last abdominal segment of the adults (1-2 mm long), which indicates their sex, by observing the adults resting on a transparent surface.</p> <p>- Cage condition: It is desirable to be able to detect problems in the cages: leaking water supply system, mortality of adults at the base of the cage, etc.</p>	<p>- Take images of the OS after the emergence of the neonate larvae, so that we can know the number of clusters that have been fertilised. Their shape and colour allow this differentiation to be carried out after the emergence of the neonate larvae, and this data can be cross-referenced with the weight of the substrate at that time.</p> <p>- Number of neonate larvae just hatched</p>	<p>- Count seeding rate; length of neonates distribution; diameter: the average diameter and diameter distribution</p> <p>- Taking thermal photographs to check the temperature distribution within the substrate, and to correlate this data with the temperature collected by the temperature sensor in the crate, and the temperature sensor in the room.</p>	<p>- Taking thermal photographs to check the temperature distribution within the substrate, and to correlate this data with the temperature collected by the temperature sensor in the crate, and the temperature sensor in the room.</p>	<p>- Black/white color larvae ratio</p> <p>- Larvae counting</p>	<p>agitation of the contents of the container (shaking the container, or introducing a tool), gives us information of:</p> <ol style="list-style-type: none"> <li>1. Whether the substrate presents fermentation problems</li> <li>2. If the substrate is too "pasty" (and hinders the activity of the larvae)</li> <li>3. If it has a suitable colour (a darker colour usually means that it is being properly digested)</li> <li>4. If it presents pathogens colonising the substrate or the food (fungal colonies are discovered through the mycelia they develop).</li> <li>5. Identify another abnormalities</li> </ol>	<p>sample.</p> <p>- Exoskeleton quality assessment</p>
<b>SAMPLING RATE FOR AUTOMATION PURPOSE</b>						
Every 2 hours	Daily	Every 5 hours	Every 8 hours	Real time	Every 8 hours	Daily

### 4.3 Farming operations

The life cycle of the BSF is not as complicated as the other species aforementioned. Basically, each stage of development has its own requirements which are necessary to be replicated for production to be efficient. These are stage specific. In order to have a clear view of the process, a flow chart (Figure 9) is hereby provided with a detailed description of the areas concerned. Four principal areas have been identified:

1. Brood stock, where adult maturation is allowed until egg production can commence.
2. Incubation and nursery, where eggs are kept until larvae emerge.
3. Fattening, where the larvae are fed and grown until the desired size.
4. Harvesting and collection which is the final stage of the production cycle.

All the farming operations for *H.illucens* rearing process is shown in the following figure (Figure 9):



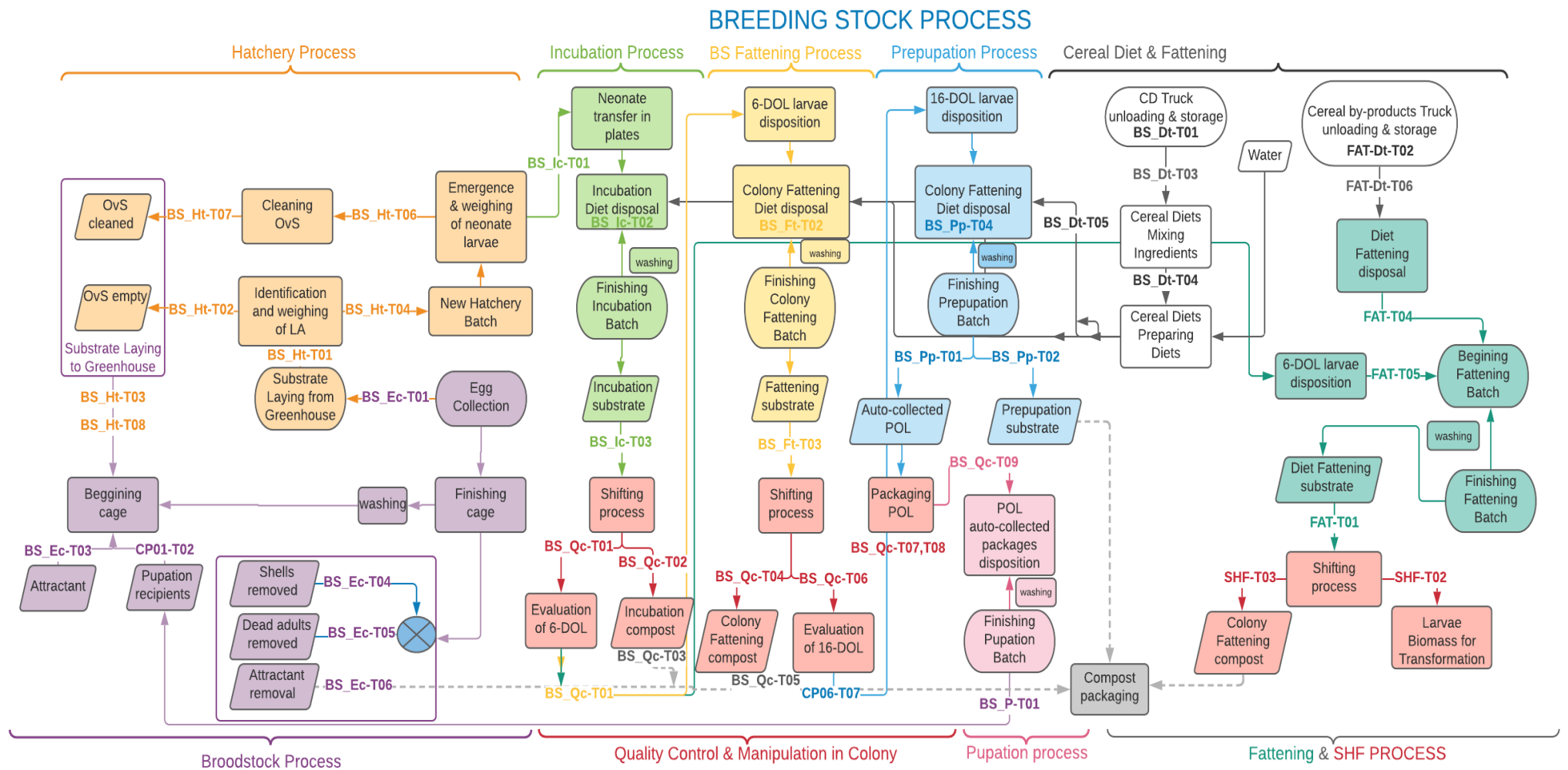

Figure 9. Flowchart of *H.illucens* rearing process.

**Brood stock (BS):** This is the unit where eggs are produced. The following tasks are executed.

- 1) **Brood stock replacement:** Adults placed in an adult environment will be harvested and culled. The enclosure will be washed and disinfected. New fresh adults will be picked when they emerge from the pupa cages, then grouped into the enclosure containing the oviposition device and a source of waste. Maintaining temperature, humidity and ventilation conditions in this process is essential.
  - a. **Egg collection:** Oviposition device (containing freshly resealed eggs) will be collected daily from the egg production rooms and replaced by an empty oviposition substrate. Females oviposit their eggs in clusters of 200 to 1000 eggs, with an average weight of 28 mg.
  - b. **Feeding:** Adults are fed with a water feeder. A constant renewal of the water source is recommended.
  - c. **Revision:** The enclosure shall be checked daily for the presence of pests, parasites, mortality or other problems. Checks for unusual mortality, attractant degradation with fungi or too wet spots, checking for pests such as mites or foreign insects will also be done.
  - d. **Cleaning and maintenance**

*Table 16. Key performance indicators for BS area.*

Key performance indicator	Value	Deviation
Adult sex ratio	M:F   52:48	Review of the pupation process. Review of batch traceability.
Percentage of adult emergence	> 97%	Review of the pupation process. Review of batch traceability. Review of the cage conditions. Review of abiotic conditions.
Prepupae presence	< 2%	Review of the pupation process. Review of batch traceability.
Female fecundity	> 82%	Review of the pupation process. Review of batch traceability. Review of the cage conditions.

- 2) **Incubation and nursery:** The unit includes the incubation of the eggs and the development of small larvae until the larvae can be sent to the fattening unit. The eggs hatch within 3 day

and the newly born larvae “jump” into the boxes underneath the device. When full, the crates will be replaced with empty ones.

- a. **Incubation:** The newly born larvae will be fed with specific feed and will be stacked for proper growth. On day 5, the larvae will be monitored and transferred to growth (rearing) feeds to provide proper growth. These crates will be moved into the fattening area with proper environmental conditions.
- b. **Feeding:** Starter feeds contain a premix to guarantee supply of minerals and vitamins to maximize survival rate, and to strengthen the larvae's ability to convert waste during the fattening phase. The feed is added one time per cycle.
- c. **Revision:** Daily revision for presence of pest or diseases that may affect the life of small larvae will be carried out. Crates with abnormalities will be marked for follow-up checking, corrected, or eliminated if necessary.

The KPI of the incubation and nursery area of BSF are shown in Table 17.

*Table 17. Key performance indicators for incubation and nursery area.*

Key performance indicator	Value	Deviation
<b>Egg hatch ratio</b>	> 91%	Review of the hatchery process. Review of batch traceability. Review of the brood stock and hatchery room conditions.
<b>Mortality ratio</b>	< 11%	Review of the incidents and observations of the batch. Review of abiotic conditions. Review of diet batches.
<b>Sieving performance</b>	> 97%	Larval assessment: detection of heterogeneity problems. Review of feeding batches. Review of abiotic conditions. Review of sieving equipment and its maintenance plan.

**BS Fattening:** This unit is for growing out the larvae from small developmental stage to harvesting size, aiming at the final production of adults for the maintenance of the breeding stock.

- d. **Feeding:** For 15 days, the larvae are fed with a cereal-based diet (60% water content), with 2 Kg/day in crates of 2,400 cm<sup>2</sup>. After the feeding has been concluded, the crates are piled back into the pallet and when the pallet is filled up with crates it is brought back to the fattening unit.
- e. **Animals counting:** Necessary for feeding adjustment. Larvae population is estimated visually to deduce the number of larvae and their developmental stage to estimate how much feed is necessary for the succeeding feedings. Too high larvae density will produce development delays and thus will need more food. Too low larvae density will use the space making feed less efficient. Crates are checked before the feeding.
- f. **Harvesting:** When larvae have reached the targeted size, the pallets with the crates are brought to the sorting sieve. There, the boxes are emptied over the sieving hopper, then sieved in the machine until all the contents of the crates are divided with larvae of different size and frass. Frass is disposed of as one of the outputs.

- g. **Quality control:** The crates which are selected for quality control are brought to the quality control area where larvae are counted, weighted, measured in dry weight, estimated, and dead individuals counted. The readings are saved for further evaluation.
- h. **Pupa collection:** Prepupae sufficiently large enough to be transformed to pupa are fed and set in the fattening room until the first pupae appear. The pallets with the crates are brought to the sorting room where Prepupae are separated from substrate. Prepupae will be placed in pupa cages and kept in the pupation area until adults start to emerge. Adults are then brought to the adult area.

Table 18 reflects the KPI of the Colony fattening area of BSF.

*Table 18. Key performance indicators of the colony fattening area of BSF.*

Key performance indicator	Value	Deviation
Larva individual weight (10 DOL)	[280 - 330 mg/L]	Review of the density of the batch. Review of feed batches. Review of abiotic conditions. Presence of substrate problems. Traceability of the batch.
Larva total biomass	Value specified according to batch size	Review of mortality in the batch. Review of feeding batches. Review of abiotic conditions. Presence of substrate problems. Traceability of the batch. Review of sieving equipment.
Mortality ratio	< 8%	Review of the state of the substrate. Review of feed batches. Start of the procedure to identify pests and diseases.
Pupa individual weight	[205 - 233 mg/L]	Review of the pupation process. Review of feed batches. Review of abiotic conditions. Presence of substrate problems. Traceability of the batch.
FCR	According to the diet used	Review of the state of the substrate. Review of feed batches. Traceability of the batch.
Feeding ratio	According to the diet used	Review of the state of the substrate. Review of feed batches. Traceability of the batch.

- 3) **Fattening:** The larval fattening process aims at transforming the larval biomass. This process is carried out in separate rooms, where the abiotic conditions are controlled, and a racking system allows the trays to be received and dispensed automatically daily.

- a. **Feeding:** For the fattening of larvae, the diet consists of a mixture of warmed cereals and vegetable by-products, with a maximum particle size of 3 mm. This facilitates larvae digestion and increases the efficiency of the fattening process. An initial feeding is given, and throughout the fattening cycle various feed inputs are made, depending on the diet used in the process. Some critical points in this process are the control of abiotic conditions in the crates, mainly by balancing larval density and the amount of food. It is also necessary to monitor larval escape.
- b. **Harvesting:** The fattening batches are collected daily. The batches are transferred to a sieving equipment, which separates the frass from the larval biomass, which is destined for processing.

Table 19 is for the KPI and Table 24 for the risks of fattening process area of BSF.

*Table 19. Key performance indicators of fattening process area.*

Key performance indicator	Value	Deviation
Larva individual weight (larva harvested)	According to the diet used	Review of the density of the batch. Review of feed batches. Review of abiotic conditions. Presence of substrate problems. Traceability of the batch.
Larva total biomass	Value specified according to batch size	Review of mortality in the batch. Review of feeding batches. Review of abiotic conditions. Presence of substrate problems. Traceability of the batch. Review of sieving equipment.
Mortality ratio	< 11%	Review of the state of the substrate. Review of feed batches. Start of the procedure to identify pests and diseases.
FCR	According to the diet used	Review of the state of the substrate. Review of feed batches. Traceability of the batch.
Feeding ratio	According to the diet used	Review of the state of the substrate. Review of feed batches. Traceability of the batch.

Table 20. Risks to be considered in the different farm areas of *Hermetia illucens* rearing process.

Risk	Value	Corrective action
Pests	Presence	Initiation of source location and eradication procedure. Differentiation according to rodents, parasites or diseases.
Toxics	Presence	Cleaning procedures. Evacuation or transfer procedures. Input replacement procedures.
Scape	Incidence	Initiation of the escape procedure according to mild, medium or high severity.

## 5. Technical specifications for *Acheta Domesticus*

### 5.1 Life cycle and physiology.

Crickets, like *Tenebrio*, is a species that has been reared in Europe for decades as live feed for pets. In the past years, its farming has been increasing, making it a key species for animal and human food. More and more commercial products for human consumption can now be found in the market. In fact, crickets have been part of the annals for history as part of the gastronomy of various Oriental countries.

This section has the same structure of information to species aforementioned.

The common house cricket or *Ancheta domesticus* is native to Southwestern Asia. It has been farmed as fish bait and food for pets. The house cricket, *Acheta domesticus* (L.) (Orthoptera: Gryllidae), is one of the most important insect species being produced commercially in the USA for feed and food. The life cycle is hemimetabolous, with nymphs eating the same foods as adults [36]. The description of the different stages of *A. domesticus* is featured in Table 21, Table 22 development parameters, Table 23 and Table 24 shows environmental conditions and Table 25 the body weight metrics.

Table 21. Life cycle of *A.domesticus*.

STAGE	IMAGE
<p>Adult: They are typically grey or brownish in colour, grow up to 16-21 mm in length, have long hind limbs which are sometimes shed later. The three insect tagmata are the anterior head, thorax and posterior abdomen. The head has no external signs of segmentation and bears 3 pairs of legs, antennae, mouth and mouthparts. The thorax is larger and bears the digestive, excretory, reproductive viscera and appendages, when present, are specialized for copulation or oviposition. Most abdominal segments lack appendages and those present are highly modified. The body is covered by an elaborate and well-developed integument consisting of a monolayer of epidermis and a cuticle.</p>	 <p>Female Male</p>



<p>The difference between and female is the presence of the long ovipositor on the abdominal area</p>	 <p>Figure 10. Adult stage of <i>A. domesticus</i></p>
<p>Eggs: Cricket females lay their eggs in groups in humid soil. The incubation takes 10 to 13 days. One gram of eggs may contain approximately 1600 eggs.</p> <p>Large females of <i>A. domesticus</i> produce a much higher total number of eggs than small females.</p>	 <p>Figure 11. Eggs stage of <i>A. domesticus</i></p>
<p>Nymphs: There is no larval stage thus the nymphs resemble adults when hatched. Temperature strongly influences the rate of development (the rate of morphological change) and growth (the rate of mass increase), with higher temperatures leading to faster rates if temperature remains within the viable development range for that organism [37]. Crickets raised at 28°C reached maturity after 49 days while those raised at 25°C reached maturity after 119 days.</p> <p>Nymphs pass 7-12 instars prior to reaching maturity [38]. The optimal age to harvest based on food consumption and cricket biomass gain ratios was at the end of 8 weeks at 27 °C and at the end of 6 weeks at 29 °C [39].</p> <p>Towards the last moult, a cricket weighs about 0.25g.</p>	 <p>Figure 12. Nymphs stage of <i>A. domesticus</i></p>

Table 22. Developmental parameters for crickets raised at 30°C [40].

Developmental life cycle parameters	
Number of instars	8-9
Days to last molt	45
Duration to next to last instar (days)	5
Duration of last nymph instar (days)	8

<b>Life span of adult virgin female (days)</b>	88 + 2 33 days (Lundy and Parrella, 2015) 120 at 30°C (Lyn et al, 2011)
<b>Oviposition period (days)</b>	60-70
<b>Age when egg laying begins</b>	9
<b>Total egg production (n° of eggs)</b>	2994 + 245 (7)
<b>Egg incubation period (days)</b>	13

Table 23. Minimum, maximum, and optimal temperature (°C) conditions used on the rearing of eggs and adults of crickets.

<b>Temperature (°C)</b>			
	<b>Minimum</b>	<b>Average</b>	<b>Maximum</b>
<b>Eggs</b>	15-17	25-27	35
<b>Adult</b>	10	25	35

Table 24. Minimum, maximum, and optimal relative humidity (%) conditions on the rearing of eggs and adults of crickets.

<b>Relative Humidity (%)</b>			
	<b>Minimum</b>	<b>Average</b>	<b>Maximum</b>
<b>Eggs</b>	12	60-75	98
<b>Adult</b>	12-20	90-100	98

Table 25. Average body weight of next to last and last instar and adult crickets at a rearing temperature of 30°C [40].

<b>Instar</b>	<b>Day</b>	<b>Female (mg)</b>	<b>Male (mg)</b>
<b>Next to last</b>	1	210 ± 3	-
	3	181 ± 3	-
	5	184 ± 3	-
<b>Last</b>	1	200 ± 4	247 ± 5
	3	364 ± 5	318 ± 6
	6	370 ± 4	356 ± 7
<b>Adult virgin</b>	0	400 ± 14	368 ± 5
	5	499 ± 29	415 ± 8
	10	555 ± 35	408 ± 7
	16	589 ± 35	398 ± 7



## 5.2 Production requirements

**Based on the compiled information from ICF** as representative of the rearing of crickets in the CoRoSect Project, the structure is basically the same as the aforementioned species of insects yet it is quite different in terms of management.

Requirements of the life cycle of *A. domesticus* are shown in the following table:

Table 26. Requirements to life cycle of *A.domesticus*

1.ASSEMBLE THE BIRD DRINKER	2.CHECK THE AVERAGE SIZE OF CRICKETS	3.CHECK THE QUANTITY OF CRICKETS	4.CHECK THE PRESENCE OF PESTS	5.CHECK THE PRESENCE OF FEED
<b>THE LIFE-CYCLE INSTAR</b>				
Day 1 to Adult	Day 20 to Adult		Day 1 to Adult	
<b>ABIOTIC CONDITIONS (TA   HUMIDITY   PHOTOPERIOD L:D)</b>				
[Broodstock Area] 28 °C   50%   10:14 [Incubation & Nursery Area] 30 °C   90%   10:14	[Broodstock Area] 28 °C   50%   10:14	[Broodstock Area] 28 °C   50%   10:14	[Broodstock Area] 28 °C   50%   10:14 [Incubation & Nursery Area] 30 °C   90%   10:14	
<b>SIZE OF INSECT AT THE GIVEN LIFE CYCLE STAGE</b>				
0.1 – 2 cm	0.7 – 2 cm		0.1 – 2 cm	
<b>PARAMETERS MONITORED</b>				
- The shortage of water in the water tanks. - Presence of flies and midges. - Presence of mould.	- Size of the crickets.	- Amount of Acheta per crate.	- Presence/absence of dermestidae.	- Presence of feed inside the trays, when this is absent should be filled.
<b>TASK PROPERTIES AND METRICS, FOR QUALITY CONTROL AND AUTOMATION PURPOSE</b>				
As far as the presence of flies is concerned, up to 3 larvae or 2 pupae per water tank can be considered an acceptable amount that does not require intervention.	<ul style="list-style-type: none"> <li>- From day 1 to day 19: monitoring the environmental conditions, no operations are carried out at this stage.</li> <li>- From day 20 onwards, measurements are essential and the size, homogeneity of development and quantity per crate are evaluated.</li> <li>- The most important points in the development of the crickets are: the 20th day, the 40th day and the 60th day, from which point onwards the cricket is an adult and no longer grows. Surveys are still carried out on the 80th day for those crickets that are destined for reproduction.</li> <li>- Number of insects per day x, with a weight of 0.6. The values follow the birth chart.</li> <li>- Average size per day x, with a value of 0.6. The values follow the sizes shown in the chart.</li> <li>- Deviation from the average size, with a value of 0,2. Calculation of the standard deviation of the average size of the crickets in the crate. These three values give an index of 0:1, thanks to which the operator can immediately understand the state of the Crate and if he wants to analyze the individual metrics.</li> </ul>			<p>Two lines of reasoning can be followed for filling the trays with food:</p> <ol style="list-style-type: none"> <li>1) through the identification of the empty trays these are filled with 600 g of feed.</li> <li>2) A suitable index may be provided to allow us to understand how much and when food should be administered, based on the metrics previously exposed.</li> </ol>
<b>SAMPLING RATE FOR AUTOMATION PURPOSE</b>				
Water content is monitored daily	Once every 3 days		Randomly but daily	Every three days

## 5.3 Farming operations

The life cycle of *Acheta domesticus* (Crickets) is very simple in terms of work distribution, being those operations similar from the day the hatchlings emerge from the egg until the recollection of eggs from the adults. Like previous sections, a flowchart is provided to have a clear view of the production process, and then a detailed description of each area of production is included. There are four working areas in the production cycle:

1. Brood stock, where adults mature until they produce eggs.
2. Hatchery, where the eggs are incubated until the small crickets emerge.
3. Fattening, where the nymphs are kept until the desired size.
4. Harvesting, where the individuals are collected and eviscerated before processing.

All the farming operations for *A. domesticus* rearing process is shown in Figure 13:

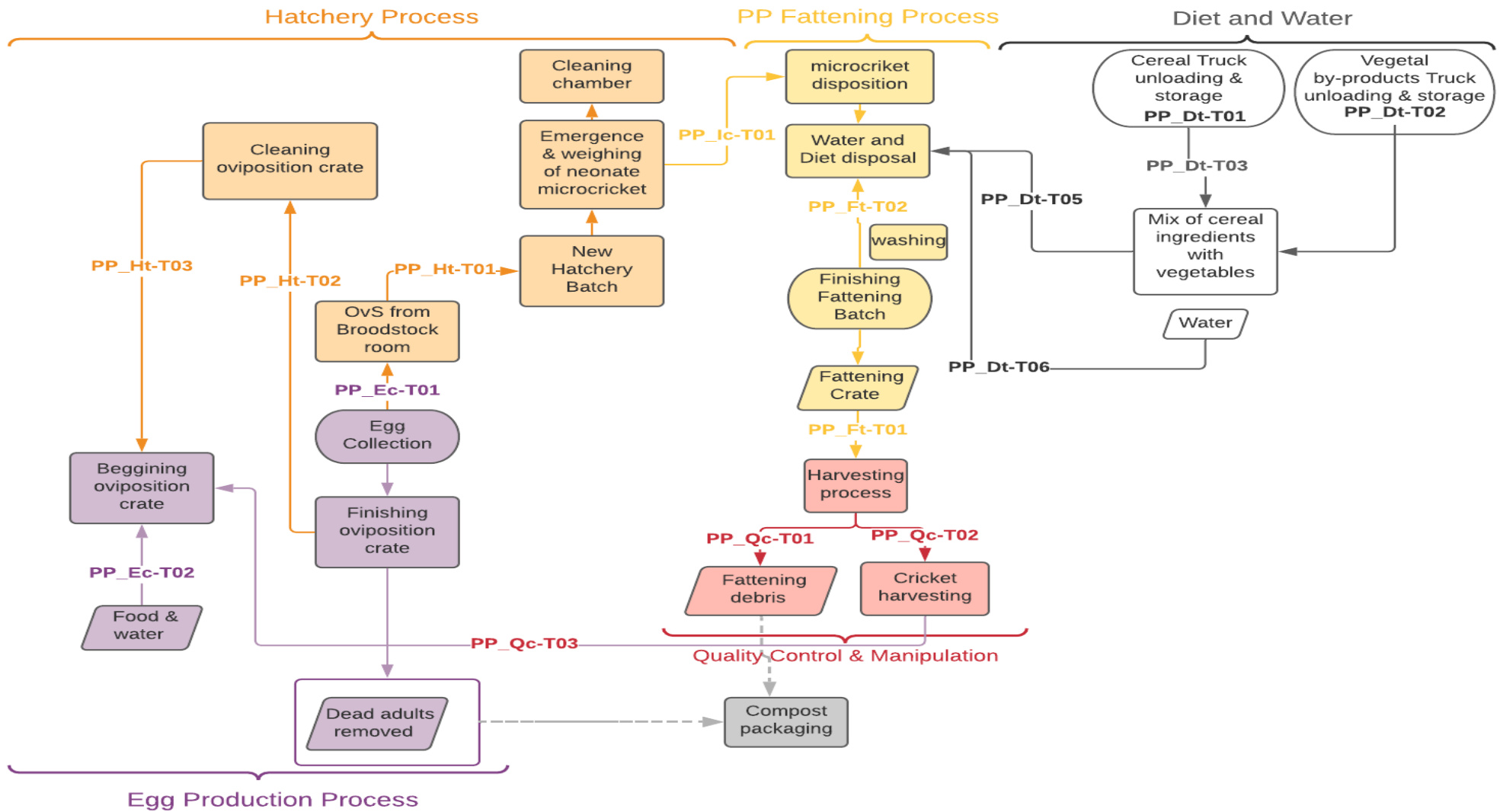

Figure 13. Flowchart of *A. domesticus* rearing process.

**Brood stock (BS):** This is the unit where eggs will be produced. The duration period is 25 days, which consists of a pre-oviposition period of 6 days, and the oviposition period of 19 days.

1. **Brood stock replacement:** Adults (day 25 of the breeding cycle; 85 days from hatching), are placed in oviposition devices. Those which are too old to perform sufficient oviposition are culled. The crates are disposed of and brought to the cleaning area.

New, fresh adults from the fattening area are picked when they emerge from the nymph crates and will be then grouped in a new oviposition device containing the oviposition substrate (a mix of vermiculite and peat moss), dispersal material (cardboard structures), water source (3 bird waterers), and food trays (3 trays). The oviposition devices are located at brood stock rooms.

Reproductive capacity peaks on the 17th day (female fertility peak). To optimize fertility, three shifts will be created depending on female maturity.

- a. **Egg collection:** At day 8 of the crate cycle, new oviposition trays (containing peat) are placed in the oviposition crate. After 24 hours, the oviposition trays (with peat) inside the oviposition crate are removed. This is done daily, replacing with new ones in order to have a maximum of "24h egg's age" gap. The oviposition trays are then brought to the incubation room/nursery.
- b. **Feeding and watering:** Adults are fed with a dry source of feed (normally cereal grains and other proteins) and supplemented with a source of easily digested carbohydrates and vitamins such as potatoes, carrots or apples. As a water source, bird waterers that comply with sanitation regulations are used. The water feeders are removed daily and substituted for a new one. Deteriorated vegetables are retrieved, and feed is replenished.
- c. **Revision:** Oviposition devices are inspected daily to check if everything is going accordingly. Signs of pest, diseases, or other hazards are marked or eliminated if needed. Checks for unusual mortality, substrate degradation with fungi or too wet areas are checked for pests such as mites or foreign insects.
- d. **Cleaning and maintenance:** Floor and crates will be cleaned periodically whenever the cycle is concluded (day 25). Crates will be cleaned following the removal of the internal structures (dispersal material, waterers, and feeding trays), removing all the organic waste with the use of a high-pressure washer.

Table 27 shows the key performance indicators of the brood stock area of Crickets and Table 30 is to indicate the risks in the BS area of crickets.

Table 27. Key performance indicator of the BS area of crickets.

Key performance indicator	Value	Deviation
Sex ratio	M:F   50:50	If the ratio becomes 70% female, testing for Acheta domesticus Densovirus is carried out.
Daily mortality ratio	<10%	Action: removing the crate and analysing the factors that may have influenced it.
Female fecundity	About 100 eggs per female every 3 days	Review the condition of the incubator and breeding stock.

2. **Hatchery:** This unit is for the incubation of the eggs and the development of small nymphs until they can be sent to the fattening unit. The duration is about 13 days. Hatching occurs on day 9 (peaks on day 9) and last emergence occurs on day 13. One gram of micro crickets is composed of 1,600 individuals, approximately.
- a. **Incubation:** Oviposition trays proceeding from the brood stock, containing the peat substrate with the eggs, will be placed inside the incubation unit for hatching. When the nymphs emerge, they will fall into the boxes located at the bottom part of the hatchery, where holding boxes with dispersal material and potato slices will hold the micro-crickets until they can be stocked in the fattening room.
  - b. **Feeding:** There is no feeding operation in the hatchery/nursery.
  - c. **Revision:** Daily monitoring for presence of pest or diseases, which could affect the life of the little larvae, will be carried out. Boxes with abnormalities will be marked for reassessment, will be corrected, or eliminated if required.

Table 28. Key performance indicator of the Incubation/hatchery area crickets.

Key performance indicator	Value	Deviation
Emergence	Production less than 2kg microcrickets/day	Actions: Analysis of the laying medium. Analysis of the conditions in the incubator. Analysis of the adults (broodstock).
Daily mortality ratio	<30%	Actions: Analysis of the laying medium. Analysis of the conditions in the incubator. Analysis of the adults (broodstock).
Hatching time	<10 days	Actions: Analysis of the laying medium. Analysis of the conditions in the incubator. Analysis of the adults (broodstock).

### 3. Fattening:

This unit is the grow-out phase, where nymphs from small-sized developmental stage will be maintained until harvesting size or adult. The duration period is 60-85 days, depending on the harvesting size. About 100 gr. of micro-cricket will be placed in the crates, and this batch will be kept during the complete fattening cycle.

- a. **Feeding and watering:** Upon entering the fattening unit from the nymph (stage I), they will be fed once during the first 15 days with 1.8kg of feed/crate; twice a week at day 16 to day 40 with 0.6 kg of feed/crate; and twice a week from day 41 to day 60 and with beyond with 1.2 kg of feed/crate. For young crickets, potatoes will be administered to add humidity, nutrients, and palatability. A diet of mineral salts, carbohydrates, lysine, methionine, proteins, phosphorus and vitamin B12 is highly recommended.  
Personnel walking through the unit will remove the depleted feeding trays and bird waterers and substitute them with new feeding trays with fresh food and clean bird waterers. Used recipients will be sent to the washing room. The water will be changed every 4 days. As the tasks of checking the feed and water supply are very labour-intensive, they therefore must be automated, at the same time having standardized automation of the process.
- b. **Animals counting:** As a necessity for feeding adjustment, nymphs' population will be estimated visually to deduce the number of individuals and development stage to estimate how much feed is necessary for succeeding feedings. Too high nymph density will produce delays in their development and more food will be needed. Too low larvae density will use up the space and feeding will be less efficient. Crates will be checked before feeding.
- c. **Harvesting:** This is done when individuals reach the targeted harvesting size. Larvae which have reached the targeted size will be brought to the harvesting area. The cardboards where crickets hang will be shaken, and the top of the box will be tapped so that the individuals will fall and therefore can be collected. The box will be stored in a cold room until the individuals are either packed (alive) or slaughtered for further processing.
- d. **Quality control:** The crates which are selected for quality control will be brought to the quality control area where individuals will be counted, weighted, measured for dry weight, estimated, and dead animals counted. The readings will be saved for evaluation.
- e. **Cleaning and maintenance:** Floor cleaning periodically and crates when the individuals are harvested (similar to the cleaning of adults crates).

Key performance indicators of the fattening area of crickets is reflected in Table 29 and Table 30 shows the risk of the fattening

Table 29. Key performance indicator of the fattening area of crickets.

Key performance indicator	Value	Deviation
Density (visual inspection)	1 ind./2,5 cm <sup>2</sup>	Action: Crate is analysed and if no pathogens are found, no action is taken.

Table 30. Risks to be considered in the BS and fattening areas of crickets.

Risk	Value	Corrective action
Diet humidity	5-10%	Action: feed batch is discarded.
Pests (parasites, diseases...)	Presence of <i>dermestidae</i>	Action: Elimination of 'infected' crate, rapid emptying of breeding room
Photoperiod control failure	Anomalies in the correct development of the insect's biogenic cycle	Action: Reactivating the correct photoperiod

## 6. Technical requirements and technology implementation.

The previous sections show information related to the biological description and process in each reared species, but no mention was made with respect to the machinery and equipment necessary to carry out the work. A description of those machineries and equipment is detailed in the technological aspects of the farm. The first subsection describes three key systems that **must be implemented throughout the farm**, which are climate control, sorting and harvesting, and feed preparation and feeding. These three systems have been selected to be incorporated in the CoRoSect Farm. They are in need of an improvement in terms of technology for the mere fact that these areas require a great amount of manual labour, because a good number of parameters have to be managed with the use of artificial intelligence, and because quality and efficiency can be improved greatly if newly proposed technologies can be implemented. Moreover, these three subsystems can be interconnected with control system for improving all the parameters. This subsection therefore details which is present, or rather a kind of a state-of-the-art, so that the technological partners can have an idea of which elements can be interconnected. In subsection 2, a detailed enumeration of **elements which are in closer contact with the insect rearing** to best describe **which can be substituted**, for example, the work done by a human using a forklift can be substituted by Automated Guided Vehicles (AGVs). The last subsection includes a proposal for a substitution of the elements described by a cyber-component, the farm integration of which will be developed in future deliverables.

### 6.1. General systems and components

Modern insect farming can be more tedious than any other farming activity in the sense that more technical aspects need to be considered in the whole process. First and foremost, insects are ectothermic, and environmental conditions greatly affect their development. A good climate control



system is the key to achieve optimum results during the rearing process. Due to the passing of seasons in any temperate country, fluctuations in temperature are detrimental thus stability in climate conditions inside the farm results in a consistent production year-round. Certain life stages are absolutely dependent on specific temperature ranges, humidity and light, and slight changes may hamper or impair insect development in the various stages in their life cycle.

Feed preparation and feeding is done in bulk, speaking in tens of tons of feed per day. The task requires machinery and a flow system for moving volumes of feed from truck to crate. This may consume a lot of energy, space and other sources, and having a good design will lessen the energy variables, as well as the Capital Expenditure and Operating expense.

Harvesting is crucial to the end state of the product. The insects harvested must be in good condition, structurally intact in terms of complete appendages and the entire body in top condition in general.

In this section, three core systems (climate control, harvesting and sorting, feed preparation) and their corresponding elements are described in passing, touching on basic principles, with the intention of simple showing the flow for the purpose of linking these systems when designing other subsystems of the CoRoSect farm (internal logistics with AGVs, artificial intelligence, sensors and robotic systems).

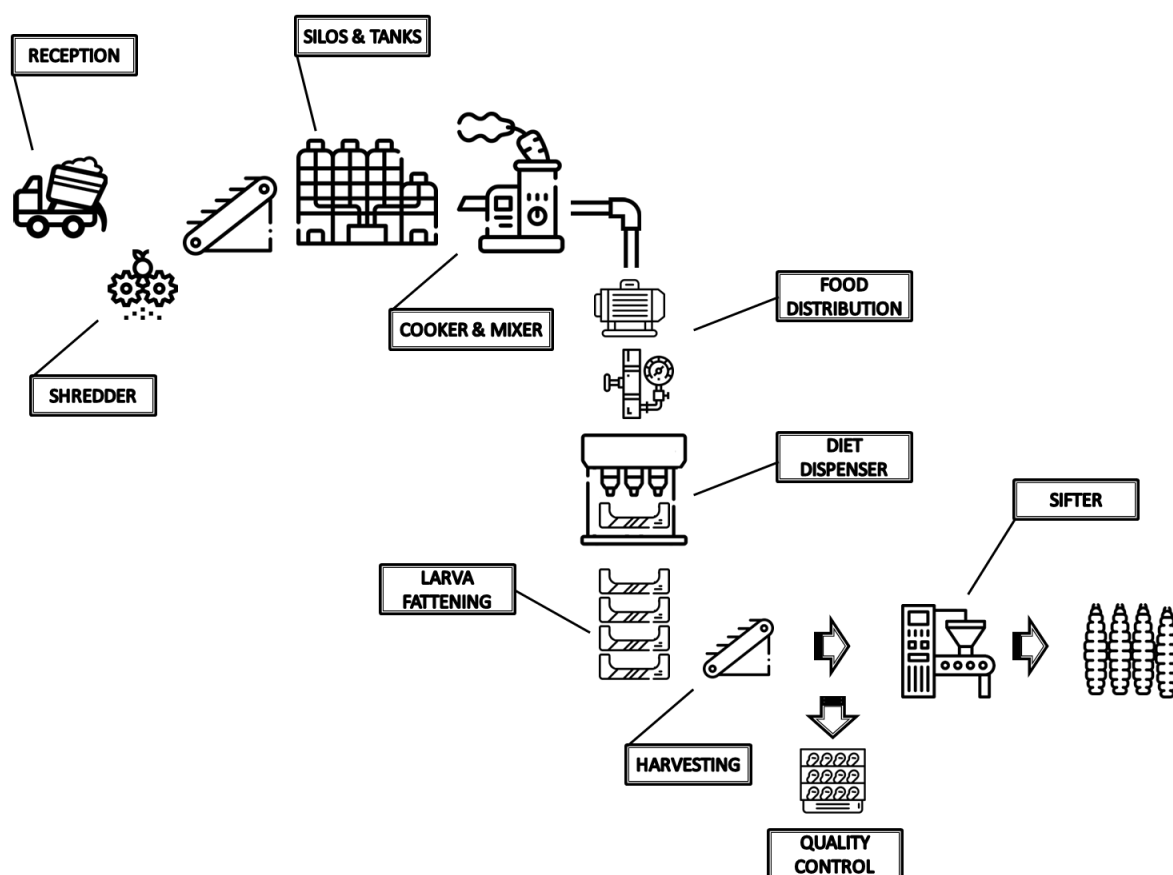

Figure 14. General Process Flow-Chart In Insect Farming

### 6.1.1 Climate control:





Climate control is an important aspect to consider when raising insects. There are several factors concerning climate control. First is **temperature**. Insects are mainly ectotherms, to a certain extent, in a sense that their development directly depends on the external temperature. Each species has an optimum temperature or range where maximum growth can be achieved. Temperatures above the optimum may speed up growth, however, they are also associated with higher mortality rates, increase incidences of developmental deformities, and population collapse. If the temperature is too high, the individuals may not be able to adapt. On the opposite end, when the temperatures are low the development slows down, and with extremely low temperatures they die. Second factor to consider is **humidity**, which also impacts their development. It affects egg hatching, causes difficulties during moulting, oviposition inhibition or death. Humidity may only affect one stage more severely than another. Lastly, insects need adequate ventilation for proper development. Certain functions may be arrested if **CO<sub>2</sub>** surpasses certain levels.

The challenge in climate control, otherwise known as Humidity Ventilation and Air Conditioning (HVAC), is to maintain and control CO<sub>2</sub> at a certain level (set point) while keeping temperature and humidity as stable as possible, with minimum use of energy so as not to affect production cost.

Table 31 shows the components of the AVAC installation for air movement and air treatment and Table 32 the component for control system wiring and pippig

**Elements to be considered for efficient HVAC are as follows:**

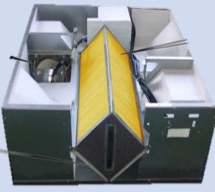
*Table 31. Components of an HVAC installation*



Air Movement		Air treatment		
Ventilation exhaust	Grids and fans	Enthalpic recuperator	Humidifier	Industrial chiller
CCS.1	CCS.2	CCS.3	CCS.4	CCS.5
 <p><i>Figure 15. Ventilation exhaust.</i></p>	 <p><i>Figure 16. Grids and fans.</i></p>	 <p><i>Figure 17. Enthalpic recuperator.</i></p>	 <p><i>Figure 18. Humidifier.</i></p>	 <p><i>Figure 19. Industrial chiller.</i></p>

- **CCS.1. Ventilation for air refreshment/renovation:** Air renewal is usually subjected to a CO<sub>2</sub> setpoint which shouldn't be exceeded to avoid death or deterioration of the population, and to avoid interfering with the performance of the production system. There are two ways to renew air. One is to continuously renew air by means of controlling the speed of the impeller and extractor turbines, using turbines in the ducts, so that the abiotic conditions of the rooms will not be abruptly altered. The other is by renewing the air in batches using an "on/off" procedure, which produces peaks in temperature and humidity. This method is counterproductive because when outside air is allowed to enter, the temperature and

humidity inside equalizes with the exterior temperature and humidity, making the need for HVAC to readjust the settings inside in order to maintain the optimum conditions for rearing.

- **CCS.2. Grids for inlet and outlet air and fans:** The location of the grids assure a good air distribution. Air tends to segregate in the top part for hot air and the lower part for cold air. The temperature gap is even more dramatic if air trajectory is intercepted by barriers such as stacked boxes or shelves, and more so when they reach the top part of the rooms. For the purpose of mixing air, and to make it as uniform as possible, fans can be placed in different parts of the room, but it is too extensive to be done in this section. However, grid location design can affect production performance by 15%, even with a well-prepared HVAC system. In addition, air segregation produces inaccurate readings of the probes.
- **CCS.3. Enthalpic recuperators:** Used as air pre-treatment. The objective is to recover the energy of the exhausted air by means of enthalpic recovery, which makes exiting air transfer heat/cold and humidity to the incoming air via a heat exchanger. If well designed, it can recover 98% of the energy. One of the advantages, obviously, is energy saving. Moreover, air enters the room at a temperature closer to the set point, reducing peaks.
- **CCS.4. Humidifiers:** There is a large diversity of humidifiers like vapor generators, ultrasonic, adiabatic panels, nebulizers (high and low pressure) and impact nebulizers. Although they could be directing humidity immediately to the rooms, best performance is obtained if they direct the humidity in the plenum first because it decreases problems concerning formation of water droplets, which in turn could affect several development stages of the insects and encourage pests and diseases. An added advantage is that, as the fully conditioned air penetrates the room, the amount of equipment in the room is reduced, avoiding maintenance of individual equipment, equipment interference with production processes, etc.
- **CCS.5. Industrial chiller:** A good way to cool down/heat up rooms is by storing heat and cold in insulated buffer liquid tanks (normally water plus glycerol). Depending on the temperature needs, the water from either tank is pumped through a coil to transfer the heat/cold to the surrounding air in the chambers. The device that is normally used is a fan coil. However, best results are obtained when air is treated outside the chambers (plenum). The device is custom made and functions by having an exterior air inlet that mixes with room air, adjusting humidity and temperature before the air enters back into the rooms. Normally there is a plenum per room or per group of rooms with similar climatic settings.

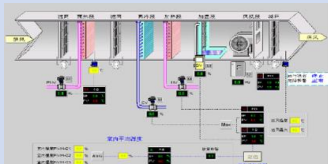
Table 32. Control system, wiring and piping.

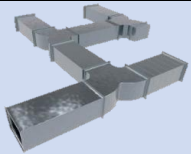
System control		Complementary	
Probes	Computer controller	Insulation panels	Air ducts
CCS.6	CCS.7	CCS.8	CCS.9
 <p>Figure 20. Probes.</p>	 <p>Figure 21. Computer controller.</p>	 <p>Figure 22. Insulation panels.</p>	 <p>Figure 23. Air ducts.</p>

- **CCS.6. Probes:** They are used to read room conditions. Normally CO<sub>2</sub>, temperature and humidity are measured by probes, the readings of which are processed in a PLC, where scheduling determines the corrective actions to be taken to maintain setpoints at safe levels. Although probes can be in several locations inside the rooms for more accurate reading, the best measurements are obtained in the plenum and in the exhaust outlet because it gives the reading of what is inside the room. Gases, hormones, or particulates may also be monitored.
- **CCS.7. Computer automatism:** is the brain of the system and is programmed with an algorithm to act depending on the probes readings. In addition, readings are saved for observations and program learning. For example, PID systems for climate control, or the use of event learning and forecasting systems, manage to "learn" from abiotic events or disturbances. In this way, a system can gradually modify its programming to achieve flatter change curves, and therefore significantly less impact on the abiotic conditions that determine the performance of the production system.
- **CCS.8. Insulation:** Insulation is essential to maintain the required temperature and humidity conditions in the room. No heat, cold, nor humidity should be lost due to the use of unsuitable insulation materials. There are a variety of insulation materials available, the most common of which are refrigeration panels, sandwich panels, or expanded polystyrene insulation panels. If the insulated installation is carried out inside a building, panels with a thickness of 60 to 80 mm can be chosen. When the construction is done directly outside, a thickness of 100 mm is recommended for temperatures of 15 to 40 °C, while 120 mm for temperatures below 15 °C (hibernation rooms, diet storage rooms, etc.). Floor insulation is also crucial and must be compatible with the weight that is to be supported, the activities to be carried out on it, as well as the option of installing underfloor heating for temperature control. Activities to be carried out with AGVs will require floors without large slopes inside the room, or roughness such as that provided by a refrigeration panel. Likewise, the use of totally sealed drains is recommended to prevent temperature and humidity leakage.

### 6.1.2. Sorting and harvesting:

At a certain part of the production the insects have to be sorted from the crates and separated from the substrate. This process is not critical for the production itself, however it makes the process less efficient. A good harvesting process should not harm the insects. It should reduce the incidence of broken legs and antennae, or body burst because all these damages will revert to a poor product quality or production inconsistencies. The process of harvesting depends on the type of insect produced and the development stage. Mass rearing of insects is normally done with insects incorporated in the substrate, thus part of the harvesting process depends on sieving larvae from the frass. Bad sieving may leave insects in the frass portion, which is detrimental to sales. According to EU regulations, frass to be sold should have less than 3% of insects present in the component. Furthermore, bad sieving may also include an ample portion of frass with the insects being harvested, which is basically a form of contamination of the end product.

The process of harvesting starts with the selection of the material from the fattening area, then later transported to the harvesting room where the crates are emptied in the harvesting system.





There are other processes which also need the same equipment used during harvesting for sorting and debris removal. For example, along the fattening process, some sorting is needed to separate

big larvae from small ones, since they grow at different rates. The larvae can then be segregated according to size in new crates with fresh food, or simply sold at different sizes to satisfy different demands.

Table 33 shows the elements for transport used in the insect farm. Table 34 describes the devices used in the harvesting, sorting and packing.



The elements normally used in the sorting and harvesting process are:

Table 33. Elements for transport.

TRANSPORT				
Crate Dumper	Pneumatic conveyor	Hopper	Palletizer	Forklifts
SH.1	SH.2	SH.3	SH.4	SH.5
 <p>Figure 24. Crate Dumper.</p>	 <p>Figure 25. Pneumatic conveyor.</p>	 <p>Figure 26. Hopper.</p>	 <p>Figure 27. Palletizer.</p>	 <p>Figure 28. Forklifts.</p>

- **SH.1. Box/crate dumper:** When insects are ready for harvesting, the pallets with the crates are transported to the sorting area where the box dumper, a device which helps to flip the crates over the hopper, empty the content. The task can be done manually. However, if crates are heavy and emptying needs to be done repetitively, a dumper is an option to facilitate the chore.
- **SH.2. Pneumatic conveyor:** The device is very handy in transporting dry, flowing products such as grains, from one point to another. It acts like a vacuum, sucking the product into the tube, and propelling it at the other end. It is very useful for insect harvesting since it can pick up substrate and insects from the crates using pressured air. Several advantages include, 1) it can bring substrate from one side to another through pipes without the need of moving pallets; 2) the substrate gets loosened and is less compact; 3) the substrate lose humidity facilitating ease of segregation in the sieving machine; 4) since the substrate travel through pipes, the pipes can be arranged in any form, shape, or position, normally positioned the on the ceiling the leaving the floor free for movement.
- **SH4 and SH5:** They are equipment used to move heavy loads between the different points of the farm. A more detailed explanation of the technical requirements of this type of component is given in section 6.2.3.

Table 34. Sieving and packing machines.

PROCESS	
Sieving machine	Packing machine
SH.5	SH.6
 <p>Figure 29. Sieving machine.</p>	 <p>Figure 30. Packing machine.</p>

- **SH.5. Sieving machine:** One of the most important process, when harvesting the insects that is being produced, is the separation of detritus and other impurities (feed residues, clumps of detritus, insects of inappropriate size, etc.). For this purpose, sieves of various types are used, particularly those which are adapted to fulfil certain purposes depending on the conditions. They usually have several mesh levels, which allow the separation of larger impurities, larvae of different sizes, and fine detritus generated during the digestion process. The sieves should be chosen with caution. Extremely high speeds of the sieves can damage the insect which are contact with the mesh. For example, in the case of crickets, their direct sale for human consumption may be visually impaired if individuals lose their wings, legs or antennae during the sieving process. For some species like the BSF, the vibration speed must be adjusted, since at low vibration speeds, the larvae tend to penetrate through the holes in the mesh and become trapped.

Some recommended models are:

- **Orbital sieving machines.** These are circular machines, usually with several levels to obtain various stages of the process. They are suitable for screening non-paste substrates at a humidity of less than 60%. When humidity is between 45 and 60%, installation of support structures, such as rubber balls in the densest sieving level, is recommended to avoid clogging of the mesh.
- **Horizontal sieves:** Ideal for large volumes of substrate. They allow the installation of several sieving levels, together with other accessories. For example, it is easy to adapt them with compressed air valves, which facilitate the separation of certain undesirable impurities, or with smaller individuals, by throwing them out of the sieving area, so as not to interfere with the collected biomass. They also allow the coupling of various mesh sizes along the screening path, or separation profiles depending on the density of the product to be screened.
- **Elastic mesh or flip-flop vibratory screeners:** The mesh of this equipment is made of high-strength elastic polyurethane, and the shape (and size) of their holes can be pre-designed according to the type of product to be screened. The elasticity of the mesh gives them the capacity to sieve very wet (>60%) or pasty substrates, allowing the substrate to travel at considerable distance while being "stretched", so that only

individuals of the right size pass through the mesh. These meshes can be installed upstream or downstream of other screening processes, making them highly versatile.

- **SH.6. Packing:** The device is to pack the product proceeding from the sieving machine, and can pack in buckets, sacs, big bags or boxes depending on product requirements . In the case of frass it is piled or packed as fertilizer.



### 6.1.3. Feed preparation and feeding.

Feeding is one of the most intense activities in terms of labour and movement. For instance, a medium scale *H. illucens* farm might need to move 50 tons of food a day to produce 6 to 10 tons of fresh larva biomass. Thus, to handle those volumes, certain equipment is used to gain efficiency. The following are recommended for the feeding system.

Table 35 shows the elements for feedstock reception, Table 36 the elements used in feed preparation, and table 37 the elements used in diet (feed) movement and distribution

**The elements normally used in the feeding process are:**

*Table 35. Feeding units.*

FEEDSTOCK RECEPTION		
Reception hopper	Silo	Tank
FS.1	FS.2	FS.3
 <p><i>Figure 31. Reception hopper.</i></p>	 <p><i>Figure 32. Silo.</i></p>	 <p><i>Figure 33. Tank.</i></p>

- **FS.1. Feedstock reception hoppers:** As feedstock is received, it should be downloaded in hoppers for later use, or in combination with bunker conveyors. Although the amount, size, and characteristics may change, depending on the feedstock used and the needs of the system, some factors need to be considered:
  - In the case of using dry and wet feedstock in the same facility, it is recommended to use at least a hopper per each type (wet and dry) since feedstocks will be stored separately and used in different proportions and in different times.
  - In the case of wet feedstock, a hopper with a mixer is highly recommended to homogenize the feedstock before being used in the system.
  - If the feedstock is not going to be treated before entering the rooms(sub-optimal), at least install a tight cover to the hopper to prevent massive infestation with other insects.



An important consideration for the hopper of wet ingredients is to use compatible materials with food preparation, using for instance stainless steel (AISI 304, AISI 316, or AISI 430) or lined with food compatible resins (epoxy for instance). In the case of using plastic materials, use those compatible with food grade and little elements transferring to the food. This premise is applicable to all the elements which work in contact with the feeds under wet conditions.



- **FS.2 & FS.3. Silos and tanks:** Feedstock is transported normally to a storage area. This is desirable since the amount of feed may vary from day to day, as well as its use may change depending on the production planning or certain needs. However, like in the previous section, it is recommended to separate the storage of dry and wet feed. The best way to store the dry feed is in silos. For wet feed, tanks with agitation are the best option. If wet feed is viscous, the tanks should have horizontal volume and the axis of agitation should be horizontal as well. If wet feed is not viscous, the tank may be oriented more vertically and agitated along the vertical axis, or by other means such as reflux.

If wet feedstock preservation is relevant for quality assurance, cooling the tanks or the space where the tanks are located is necessary. Another option for wet elements is to keep them in small plastic deposits and use them as needed but it requires some other devices to handle them.

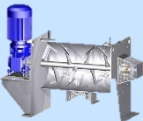
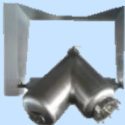
*Table 36. components for food preparation.*



FEED PREPARATION			
Mixer	Pre-Mixer	Scales	Cooker
FS.4	FS.5	FS.6	FS.7
 <p><i>Figure 34. Mixer.</i></p>	 <p><i>Figure 35. Pre-Mixer.</i></p>	 <p><i>Figure 36. Scales.</i></p>	 <p><i>Figure 37. Cooker.</i></p>

- **FS.4. Mixers:** When feedstock must be conditioned or formulated as the insect diet, it should be done in a mixer. There are two types of mixers, batch mixtures or continuous mixers. Batch mixers are the most frequently used because the entire food preparation can be done in less time (in several batches) and the implementation cost is several folds cheaper than using a continuous mixer. Among the batch type mixers, the most common ones are the horizontal paddle mixer and the drum mixer. The mixing operation usually starts by adding the wet ingredients, followed by the dry elements. When all is combined, pH can be adjusted if needed. Mixers should have an easy discharge system, allowing fast cleaning and sanitizing. Continuous mixers are recommended in large farms with an input of 200 tons/day or more.
- **FS.5. Premixer:** Normally used for the preparation of diet supplements like vitamins, minerals, diet preservatives, micronutrients, gellant agents or micronutrients. Since many of these elements can have a strong effect in the development, mixers are designed to allow even mixing with little variations.
- **FS.6. Scales:** Used during diet preparations to proportion the ingredients. To have accuracy in different ranges, use large volumes scales (kg) for bulk materials in the diet and precision scales (g or mg depending on how accurate it should be) for premixes. Truck scales (measured by 10 kg) are used for weighing incoming trucks before downloading.



- **FS.7. Cookers:** After mixing and formulating the diet, to gain uniformity and improve digestibility, it can be treated with a cooker. The idea is to raise the temperature while mixing, up to the point where foreign insects, eggs or individuals are killed, and microorganisms are deactivated. The degree of cooking depends on the need. Normally a batch treatment with long cooking for 30 minutes, at temperatures above 60 °C, eliminates pests and stops microbial growth. If temperature peaks to 70°C or above, it aids digestion. However, there is an energy cost associated with this process which could negatively affect the economical margins of the operation. Another inconvenience of cooking is the waiting period needed to reach the optimum temperature of the system (close to room temperature). An option for cookers is a heat transfer tube with screw impulsion (optionally steam injection as heat source) which can increase temperature sharply and continuously, either to temperate the diet before entering the system or to control pests and microorganisms. Feed conditioning in industrial arthropod production systems may be necessary, not only to keep the feed at a certain temperature, but also to avoid large variations in climate control systems. In a facility where several tonnes of feed must be introduced, usually at a high moisture content, feed distribution systems should be designed to ensure that feed distribution is slow.

Table 37 Feed transport.

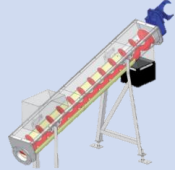
FEED TRANSPORT			
Pumps	Diet dispenser	Conveyor belt	Screw conveyor
FS.8	FS.9	FS.10	
			
<i>Figure 38. Pumps.</i>	<i>Figure 39. Diet dispenser.</i>	<i>Figure 40. Conveyor belt.</i>	<i>Figure 41. Screw conveyor.</i>

- **FS.8. Pumps:** If by any means diet must be transferred, since diets in large scale are served with a certain level of moisture normally superior to 60%, pumping is the most common way of transporting. Considering that inset diets have certain viscosity, there are two types of pumps frequently used: piston pump and screw pumps. Considering the different types of models available in the market, the model that must be selected should be adequate for food grade and high solid content products. Piston pumps are especially useful for pumping at high pressure very viscous diets but at an intermittent rate, while screw pumps are more useful for transporting at short distances, and the flux is easier to regulate. Piston pumps, however, can be used for precision dosing of small volumes (for instance to fill up a crate) while screw pumps can be used to move high volumes at high pressure. The system might use pumps at different points and can be complemented with valves for more precise use. If dry ingredients need to be moved to different feeding points, conveyors with screws can be used or pneumatic conveyors. They are based on auger lines (sometimes flexible), which are inserted inside tubes, and can run for hundreds of metres.
- **FS.9. Diet dispensers:** They are closely related to pumping. It must readjust pressure and flow in order to fill up crates as fast as possible, but not too strong to splash or overdose.

Piston dispensers are common but should be selected in a way that will deliver the desired amount with precision for the viscosity of the diet. Custom made screw dispensers allow for adjusting flow depending on speed and time. They must be more flexible if diet viscosity changes often, or when diets of different density are used in the system.

- **FS.10. Conveyor bell:** Although it is not a necessary factor in the feeding, it is normally integrated in the system. Crates are placed on a conveyor belt, and when they pass through the feed dispenser they are refilled. Distance between dispensers cannot be much lest the diet kills the insects. A way to solve this is by applying a rotary dispenser between the dispenser and the crate which will distribute the diet more evenly over the whole surface of the crate.









## 6.2. Insect farm: Requirements of technical components

Although several equipment was enumerated in the previous section, Section 6.1, those components have a more indirect relation to the rearing process. In this section further equipment or components are discussed. Components such as human intervention, waterer and feeders, cartons and crates, trays and boxes, palletizers and forklifts are in direct contact with the insects being reared and are presently being used in insect farms to ensure the success of the rearing process.

The degree of automation in farms for animal husbandry is high, as for the degree of robotization is somewhat better but more and more farms require advanced technology to improve and optimize the processes that are carried out. In the case of insects, both automation and robotization or digitization are still under-exploited disciplines, mainly due to the novelty of this production model and the low associated cost it requires.

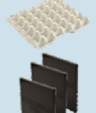
Currently the processes are tedious, repetitive, slow and have a medium level in the use of technology. In order to improve the actions in the farm tasks, it is necessary to know the main components, associated with the processes and that are used regularly in any insect breeding farm. In this way, processes can be optimized by implementing the technology proposed in the CoRoSect project, such as robotics and digitization.

Table 38. Agents involved in an insect farm.

HUMAN	TRANSPORT		CONTAINERS			BOXES		
Operator	Palletizer	Forklifts	Water	Food	Eggs	Cages	Tray	Box
 <i>Figure 42. Operator.</i>	 <i>Figure 43. Palletizer.</i>	 <i>Figure 44. Forklifts.</i>	 <i>Figure 45. Water tank.</i>	 <i>Figure 46. Feeders.</i>	 <i>Figure 47. Egg cups.</i>	 <i>Figure 48. Cages.</i>	 <i>Figure 49. Tray.</i>	 <i>Figure 50. Box.</i>

### 6.2.2. Human

Currently, the human component is a key factor for the development of tasks in insect farms. The coordination, execution and monitoring of tasks are actions that you must carry out in your day-to-day work. Associated profiles are usually field workers and laboratory technicians. The former is in charge of the most active actions during the processes, that is, preparing the environment, feeding, cleaning, etc. Regarding the second mentioned, laboratory technicians, they have an activity more focused on making decisions for actions that play a fundamental role in the life cycle of insects, such as planning periods, type of food, quantity, observations, etc.

### 6.2.3. Transport

In today's farms there is a distribution of work areas, where you can find rooms for the different breeding cycles, laboratories for associated research and a storage area for all material. This is a generic description of the main areas to take into account, in the Farming operations section of each of the species, you can see a flowchart with the description of the processes that can occur in different specific areas.

For the displacement of loads, in most cases heavy loads, such as cages, boxes or feeding, transport equipment is used, such as pallet trucks or forklifts.

- **Pallet truck:** This industrial equipment has a mechanical or hydraulic drive and is intended for the displacement of loads, concretely it is responsible for making a minimum separation from the ground by means of the forks that form its platform, thus facilitating the movement of said loads [41].

The use of this device in insect farms is mainly intended for moving the cages or boxes through the different work areas. The direction of movement and the actuation of loading and unloading are decisions made by the farm operator and are related to the task to be carried out at all times.

- **Forklifts:** The objective of this work team is similar to the previous one, but it has the ability to stack loads, thanks to the fork platform with vertical movement and whose elevation can exceed two meters. Another notable difference of this type of forklift is driving, since in this case they have a cab for the driver and a steering control.

The fundamental role of this type of vehicle within insect farms is the ability to stack loads, as in the case of insect boxes / cages or feed bags that involve large loads.

In this group of components, the technical requirements to be considered for use in insect farms are: Equipment measurements, maximum load, type of displacement, maximum elevation, risks and regulations.

### 6.2.4. Containers

This group includes all the components intended to contain or store something inside, such as water, food or eggs. Three subcategories have been classified for the most important items that require specific containers according to the species and type of item.

- **Water Tank:** Water needs a container for its correct distribution, in addition to requiring additional conditions or elements that guarantee the safety of the insect during water intake. An example of this is the water that is supplied in the form of gelatin and is deposited on some containers that resemble caps [42-44], another example for the supply of water is the use of small containers that include protection measures on water to avoid accidents and ensure the safety of the insect and the environment. Therefore, the factors to consider in the use of this component are: Dimensions, safety, hygiene and capacity.
- **Feeder:** The type of food plays a fundamental role in choosing the right container, since as mentioned in previous sections, the food can be dry or wet and can be distributed in different ways. Among one of them are the individual containers, which will contain a certain amount of food. The considerations to take into account for this element are: Dimensions, capacity and hygiene.
- **Egg cup:** These elements are usually used in some species to deposit the eggs and thus facilitate their monitoring. They are usually elements with holes that facilitate laying. Requirements such as: Type of material, dimensions and gaps must be considered.

### 6.2.5. Boxes

This category includes the different types of cages or trays that are often used to create the right environment during the life cycle of insects. Due to the characteristics of each of the species defined above and according to the stage in which they are found, one model or another that suits the needs can be used. Therefore, the three main subcategories are presented:







- **Cages:** The well-known entomological cages are intended, for the most part, for insects with the ability to fly. They are usually square or rectangular structures, covered with nylon material with an entrance that facilitates the opening and closing of different ways (zip, magnetic, belcro, etc.). The essential particularities for the adjustment of this element to the life cycle of the insect must consider an optimal design, types of materials, dimensions, interior, ventilation, entrance or type of closure.
- **Tray:** Normally they are used for the first stages of the life cycle of insects, where movement is slow or practically null, such as the larval or pupal stage. They are not usually of a great height and their shape is generally rectangular. The characteristics to be considered in this component are: type of material, dimension and capacity.
- **Box:** The boxes are similar to trays but with a much higher height, they are usually used for more advanced stages where the insect has more movement capacity and its abilities have improved, such as jumping in the case of crickets. The main characteristics to consider are the same as in the trays: type of material, dimension and capacity.

### 6.3. CoRoSect farm: Requirements of technical components

Within the scope of the 4<sup>th</sup> industrial revolution, modern industrial systems are experiencing a shift from traditional systems, i.e. dedicated lines, to changeable industrial systems at both physical and logical levels [45].

The physical components of CoRoSect are represented by the four main cyber-physical components each one capable of performing tasks within an insect farm: the Automated Guided Vehicle (AGV), the stacking - destacking robot (d-robot), the robotic manipulator (m-robot) and the intelligent crates (ICs).

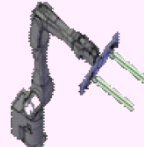
Table 39. CoRoSect agents

HUMAN	SOFTWARE	CYBERCOMPONENTS				
Operator	MES/IMS	ICs	m-robot	d-robot	Uc-AGV	Visual Inspection
 <i>Figure 51. Operator.</i>	 <i>Figure 52. PC with MES/IMS system.</i>	 <i>Figure 53. Intelligent crates.</i>	 <i>Figure 54. Manipulator robot.</i>	 <i>Figure 55. Stacker robot.</i>	 <i>Figure 56. Automated guided vehicle.</i>	 <i>Figure 57. Camera.</i>
	<b>PROVIDERS</b>					
Farm Worker	HSEL ATOS	OAMK	UM TECNOVA	ROBOTNIK	AGVR	CERTH

According to ISA-95 standard [46] this robotics is responsible for the processes on the shop floor. Operations are managed following a hierarchical structure in which a higher level, MES (Manufacturing Execution System) level, controls these cyber-physical components.

The envisaged solution for the insect farms is comprised by the concept of dynamic-cell (d-Cell). That represents a dynamic and adaptive system that is responsible for a specific task for a given time period. This system is made up of the agents that are involved in the processes of the farms and allows increasing the number of feasible tasks to be carried out.

#### 6.3.1. Human

The evolution from insect farms to smart farms where cyber-physical components operate automatically, communicating with each other and with the system, operators are free of manual tasks to be in charge of controlling that the processes are carried out in an optimal way. Co-workers have at their disposal the information provided by the system agents through dashboards with tables or diagrams, or any other interface, and from this information make decisions in farm operations.

### 6.3.2. Software

- **MES/IMS:** Manufacturing Execution System / Information Management System will be used to manage data from shop floor agents and other internal or external data sources, and to control processes performed on the farm.

The ISA-95/IEC62264 gives the generic activity model that defines the processes performed by the MES level. Orders taken by the Business Planning and Logistics level is transformed to an operation request. MES receives this operations request and manages production, is in charge of dispatching and reserving the assets involved (agents in the plant), all of this ensuring that operations are carried out at the given time.

- **Shop Floor Management:** The data collected from the assets (by the IMS) will be used by this management system that controls the performance at the shop floor.

As will be seen in the following deliverables, the digitization of the farm will result in the so-called Smart Farm (in this case, **CoRoSect Farm**) where the different levels of the automation pyramid (CIM pyramid or ISA-95 functional hierarchy) are connected, both hardware and software.

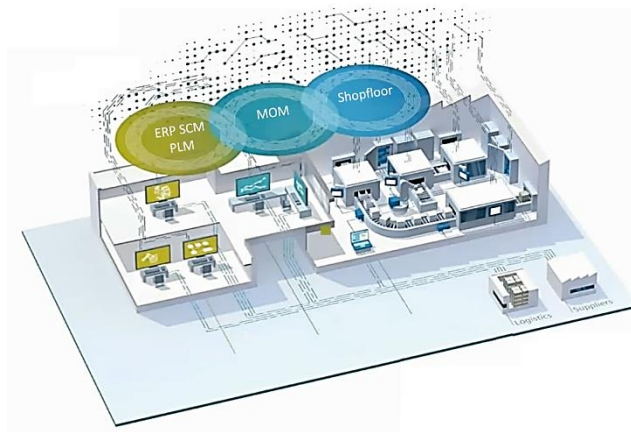

Figure 58. Smart Industry Example (Digitization)

In the Figure 58 there are three main components: (1) **ERP, SCM** and **PLM** that represent the highest level of the hierarchical structure Business Planning and Logistics (internal and external from the shop floor). (2) **MOM** or Manufacturing Operational Management composed by its Shop Floor Management (SFM) in combination with the Information Management System (IMS), also known as the CoRoSect's Manufacturing Execution System (MES). (3) **Shopfloor** where all the agents work together organized in d-cells.

### 6.3.3. Cybercomponents

- **Intelligent Crates (ICs):** Developed within CoRoSect, these intelligent crates will allow for constant measuring of environmental conditions enabling the optimization of the rearing process.

Intelligent crates are the result of integrating sensors inside the crates. The sensors will measure temperature inside the crate, relative humidity, NH<sub>3</sub> level, CO<sub>2</sub> inside or outside the crate, moisture and pH of the substrate, etc. These measurements are sent to the information management system with the purpose of knowing the state of the insects.

- **m-robot:** This robotic arm is a collaborative robot (co-bot), so it will work with the operators in the same workspace. It will comply with current security regulations (*ISO 10218-1 and ISO 13849 -1 & -2*).

In the CoRoSect farm, the m-robot will be responsible of central tasks such as preparation of the crates with the devices required, adding feed and water, inspections for quality management, handling insect, etc. For these purposes, the m-robot needs several different tools known as end effectors installed in the flange at the tip of the robotic arm. Depending on the task to be performed, the co-bot will automatically change the end-effector.

The design of this m-robot will take into account the conditions of the environment in which it operates, and therefore, the material with which this co-bot is built or the protection of the components installed in it (wires, sensors, cameras).

- **d-robot:** According to the ability to interact with humans, two options can be considered. So far, industrial robots have always been fast and robust devices, and to act safely for operators, they were performing behind safety fences and sensitive protective equipment to prevent human intrusion into their workspace. With the introduction of collaborative robots, security fences are omitted, as those co-bots can work with operators around. If a collision occurs the mechanism will stop completely to avoid causing injury [47].

Unlike the m-robot, the d-robot is only responsible for stacking and unstacking the crates: from the AGV to the conveyor belt hosted within the d-cell, or vice versa. The activation of this robotic arm will be based on communication with the AGV and the conveyor belt: once the AGV reaches the discharge area, the d-robot starts unstacking crates to the conveyor belt. When the process is complete for a crate, then the d-robot re-stacks crates on the AGV.

As in the case of the other cyber-physical components, the materials with which the robot is designed must be an important issue. In addition, its end-effector / gripper will be different according to the weight and shape of the crate.

- **uc-AGV:** Automated guided vehicles (AGV) have become an essential component in the industry. The efficiency levels of logistics is a decisive factor in companies' competitiveness, and these autonomous vehicles have the advantage of offering major potential to transform logistics chains [48]. According to the safety in the shopfloor, a study concluded that 80 % of accidents with forklifts involve pedestrian, on average 1 every 3 days [49]. Therefore, the AGV must have a certain autonomy in order to stop when an obstacle appears or change the trajectories if necessary.

In robotic insect farms, AGVs are responsible for picking up and transferring stacks of crates from storage areas, cleaning room or breeding rooms to the CoRoSect area. This component has to be able to move both empty and full crates through different areas of the farm.

For the correct performance of the under crawler - AGV it is necessary that the ground of the farm is flat and smooth. Another important issue is the doors of the rooms, they have to open automatically when the AGVs pass and the measurements of these doors for this purpose.



- **Visual Inspection System:** Cameras are required to obtain information by taking photos of the contents of the box. These cameras will be integrated into the m-robot and will take multiple shots per crate with high definition and adequate lighting to process the images.

The information collected from the visual system in CoRoSect will be: number of insects in the crate, distribution, movement, color, average size, abnormalities or non-compliant batches, food and drink levels, fertility or growth rate. These data together with those obtained by the IoT sensors (Ics) and the other assets in the shop floor correspond to the inputs for the management of the process.

Among the requirements to take into account is the degree of IP protection according to the environment of the farm such as high humidity, and the lightning needed.

## 7. Conclusions

As forementioned, insect rearing could be accepted as part of the global solution for foodstuff. Moreover, the bio-conversion process is a more logical alternative to traditional and conventional methods in the treatment of organic waste. However, mass insect rearing is a tedious activity, more so than any conventional animal farm. Attention must be paid to various factors in order to maintain a continuously smooth production chain. If the breeding facility is well done, according to technical specifications, the production output will be high resulting in a high return of investment as well. Slight alterations in any aspect of the breeding system will, on the other hand, may collapse the whole population.

Before going into the technical aspect of insect breeding, first and foremost, special attention must be given to EU legislation. The species to be reared and it's use will depend on what is legally allowed. Technical specifications related to facility construction, the materials to be used, and the breeding scheme must be in accordance with legislation, as well as animal welfare aspects. This is to ensure that no aspect of the rearing will be questioned.

The success of the rearing process will depend on compliance to species requirements. Proper knowledge of the life cycle of the species and the different requirements in different stages of growth and development is crucial for the success of the rearing. Knowledge in the manipulation of factors such as temperature, humidity, and population density may shorten or prolong the rearing time, as well as the quality of the output. Even the slightest change in certain requirements, take temperature as an example, will alter insect development and will cause delays and problems in the production in general. Changes in factors relating to growth, like ventilation, humidity and population density, may also promote the presence of unwanted bacteria and fungi which may wipe out a generation if not the whole breeding population.

Of all the insects involved in this project, the black soldier fly is the species with crucial requirements for every developmental stage, requirements which are diverse and specific for the adult, larvae, hatchlings and egg stage. The insect is greatly affected by temperature and photoperiod. In the case of *Tenebrio*, similar conditions are used for nearly all the stages, yet it's best to divide into brood stock and fattening in order to synchronize the system. The same can be said in the rearing of crickets. These differences must be taken into account when designing the climate system, assuring that the conditions in each stage are met to optimize the mating, oviposition, egg hatchability, and



initial larvae and hatchling hardening and development. During fattening, where the maximum insect biomass is achieved, in the case of Tenebrio and BSF, both live in substrates which by the end of the rearing process may be filled with waste material. However, with crickets, the food is separate from their own waste. These affect the sorting during the harvesting. BSF and Tenebrio need to be separated from the frass upon harvesting whilst for Tenebrio this separation process has to be done several times during the fattening process.

In terms of feeding, the black soldier fly is the most flexible, feeding on a wide range of food stock also allowing for a single chute feeding scheme, while crickets and Tenebrio have more specific feeding requirements. This influences the feeding scheme and the devices and elements that need to be incorporated in the system.

In terms of life cycle, Tenebrio has the longest development process, about three months from egg to adult, followed by crickets at about a month and a half, and black soldier fly for about a month. This affects the whole production timelines, as well as other the structural and cost requirements involved in rearing.

The main constraint concerns the internal logistics, the transferring of material from one side to another. Some tasks are detrimental to health, some are physically straining while material used in the rearing process maybe a source of allergens to some of the personnel. Furthermore, the different systems used in the different operational stages are not interconnected, losing efficiency in the interface. The CoRoSec project aims to explore the robotization and digitalization of the mass rearing of insects. This derivable is a base document that reflects the requirements of the farms concerning abiotic factors, logistics and operational activities needed in the rearing operation. Most of the rearing process presently done in insect farms in general is done manually or assisted by devices that still require personnel supervision. Through robotization and incorporation of artificial intelligence to the rearing process, the process will be more controlled, uniformed and less hazardous for the personnel.

## 8. References

- [1] Cadinu, L.A., Barra, P., Torre, F., Delogu, F., Madau, F.A., 2020. Insect Rearing: Potential, Challenges, and Circularity. *Sustainability*, 12(11), 4567–. doi:10.3390/su12114567
- [2] Van Huis, A., 2013. Potential of Insects as Food and Feed in Assuring Food Security. *Annual Review of Entomology*, 58(1), 563–583. doi:10.1146/annurev-ento-120811-153704
- [3] Veldkamp, T., van Duinkerken, G., van Huis, A., Lakemond, C.M.M., Ottevanger, E., Van Boekel, M.A.J.S., 2012. Insects as a sustainable feed ingredient in pig and poultry diets. A feasibility study Wageningen UR Livestock Research Report 638.
- [4] IPIFF Questionnaire on the EU market - March 2020
- [5] Bawa, M., Songsermpong, S., Kaewtapee, C., Chanput, W., 2020. Effect of Diet on the Growth Performance, Feed Conversion, and Nutrient Content of the House Cricket. *Journal of Insect Science*, 20(2)
- [6] Firmansyah, M., & Abduh, M. Y., 2019. Production of protein hydrolysate containing antioxidant activity from *Hermetia illucens*. *Heliyon*, 5(6), e02005.
- [7] Elhag, O., Zhou, D., Song, Q., Soomro, A. A., Cai, M., Zheng, L., Zhang, J., 2017. Screening, Expression, Purification and Functional Characterization of Novel Antimicrobial Peptide Genes from *Hermetia illucens* (L.). *PLOS ONE*, 12(1), e0169582.
- [8] Rivero-Pino, F., Pérez Gálvez, A. R., Espejo-Carpio, F. J., Guadix, E. M., 2020. evaluation of *Tenebrio molitor* protein as source of peptides modulating physiological processes. *Food & Function*. doi:10.1039/d0fo00734j
- [9] Gligorescu, A; Fischer, C.H; Larsen, P.F., Norgaard, J.V., Heckman, Lars-Henrik, H., 2020. Production and Optimization of *Hermetia illucens* (L.) Larvae Reared on Food Waste and Utilized as Feed Ingredient. *Sustainability*, 12(23), 9864–. doi:10.3390/su12239864
- [10] Gao, Z.; Wang, W., Lu, X., Zhu, F., Liu, W., Wang, X., Lei, C., 2019. Bioconversion performance and life table of black soldier fly (*Hermetia illucens*) on fermented maize straw. *Journal of Cleaner Production*, (), S095965261931594X–. doi:10.1016/j.jclepro.2019.05.074
- [11] Borrelli, L., Varriale, L., Dipineto L., Pace, A., Menna, L., Fioretti, A., 2021. Insect Derived Lauric Acid as Promising Alternative Strategy to Antibiotics in the Antimicrobial Resistance Scenario. *Front. Microbiol.* doi.org/10.3389/fmicb.2021.620798
- [12] Almeida, C., Rijo, P., Rosado, C., 2020. Bioactive Compounds from *Hermetia Illucens* Larvae as Natural Ingredients for Cosmetic Application. *Biomolecules*, 10(7), 976–. doi:10.3390/biom10070976
- [13] Damborsky, M., Tatiana-Bar, P.S.-Y., Oscherov, E., 1999. Ciclo de Vida de *Tenebrio molitor* (Coleoptera, Tenebrionidae) en Condiciones Experimentales. *UNNE*. 6.
- [14] Drnevich, J. M., 2003. Number of mating males and mating interval affect last-male sperm precedence in *Tenebrio molitor* L. *Animal Behaviour*, 66, 349–357

- [15] Ghaly, A.E., Alkoaik, F., 2009. The Yellow Mealworm as a Novel Source of Protein. American Journal of Agricultural and Biological Science. 4. 10.3844/ajabssp.2009.319.331.
- [16] Cotton, R.T., 1927. Notes on the biology of the mealworms *Tenebrio molitor* L. and *T. obscurus* Fab 20, 81–86.
- [17] Kim, S.Y., Park, J. Bin, Lee, Y.B., Yoon, H.J., Lee, K.Y., Kim, N.J., 2015. Growth characteristics of mealworm *Tenebrio molitor* 53, 1–5.
- [18] Hardouin, J., Mahoux, G., 2003. Zootechnie d’insectes - Elevage et utilisation au bénéfice de l’homme et de certains animaux. Bull. Semest. d’Information sur le Mini-Elevage Numéro spé, 164
- [19] Li, L.L., Stasiak, M.L., Li, L.L., Xie, B., Fu, Y., Gidzinski, D., Dixon, M., Liu, H., 2016. Rearing *Tenebrio molitor* in BLSS: Dietary fiber affects larval growth, development, and respiration characteristics. Acta Astronaut. 118, 130–136. doi:10.1016/j.actastro.2015.10.003
- [20] Siemianowska, E., Kosewska, A., Aljewicz, M., Skibniewska, K. a., Polak-Juszczak, L., Jarocki, A., Jędras, M., 2013. Larvae of mealworm (*Tenebrio molitor* L.) as European novel food. Agric. Sci. 4, 287–291. doi:10.4236/as.2013.46041.
- [21] Koo, H., Kim, S., Oh, H., Kim, J., Choi, D., Kim, D., Kim, I., 2013. Temperature-dependent Development Model of Larvae of Mealworm beetle , *Tenebrio molitor* L . ( Coleoptera : Tenebrionidae ). Korean J. Appl. Entomol. 52, 387–394.
- [22] Park, J. Bin, Choi, W.H., Kim, S.H., Jin, H.J., Han, Y.S., Kim, N.J., 2014. Developmental characteristics of *Tenebrio molitor* larvae (Coleoptera: Tenebrionidae) in different instars. Int. J. Ind. Entomol. 28, 5–9. doi: <http://dx.doi.org/10.7852/ijie.2014.28.1.5>.
- [23] Morales-Ramos, J.A., Rojas, M.G., Shapiro-Ilan, D.I., Tedders, W.L., Tedders, A.W.L., 2011. Self-selection of two diet components by *Tenebrio molitor* (Coleoptera: Tenebrionidae) larvae and its impact on fitness. Environ. Entomol. 40, 1285–94. doi:10.1603/EN10239
- [24] Gullan, P.J., Cranston, P.S., 1994. The Insects: An Outline of Entomology. London: Chapman & Hall.
- [25] Woodring, J., Roe, R.M., Clifford, C., 1977. Relation of feeding, growth, and metabolism to age in the larval, female house cricket. Journal of insect physiology. 23. 207-12. 10.1016/0022-1910(77)90031-2.
- [26] Kovac, D., Rozkosny, R., 1995. Stratiomyidae (Insecta: Diptera) of temengor forest reserve, Hulu Perak, Malasya. Malayan Nature Journal, 48, 281-285.
- [27] Gobbi, P., Martinez-Sanchez, A., Rojo, S., 2013. The effects of larval diet on adult life-history traits of the black soldier fly, *Hermetia illucens* (Diptera: Stratiomyidae). European Journal of Entomology. 110. 461-468. 10.14411/eje.2013.061.
- [28] Gobbi P., 2012. Biología reproductiva y caracterización morfológica de los estadios larvarios de *Hermetia illucens* (L., 1758) (Diptera: Stratiomyidae). Bases para su producción masiva en Europa.
- [29] Sheppard, D. C., Newton, G. L., Thompson, S., Davis, J., Gascho, G., Bramwell, K., 1998. Using soldier flies as a manure management tool for volume reduction, house fly control and

reduction, house fly control and feedstuff production (pp 51-52). (In) Sustainable Agriculture Research and Education, Southern Region, 1998 Annual Report. Gwen Roland, Editor.

- [30] Salomone, R., Saija, G., Mondello, G., Giannetto, A., 2016. Environmental impact of food waste bioconversion by insects: Application of Life Cycle Assessment to process using *Hermetia illucens*, Journal of Cleaner Production, <http://dx.doi.org/10.1016/j.jclepro.2016.06.154>
- [31] Deiner, S., Zurbrügg, C., Roa Gutierrez, F., Nguyen Dang Hong, M.A., Koottatep, T., Tockner, K., 2011 Black soldier fly for organic waste treatment – prospects and constraints. In: Waste Safe 2011 – 2<sup>nd</sup> Int. Conf. on Solid Wastemanagement in the Developing Countries, 13-15 February, Kulna, Bangladesh, pp 52-29.
- [32] Myers, H., Tomberlin, J., Lambert, B., Kattes, D., 2008. Development of Black Soldier Fly (Diptera: Stratiomyidae) Larvae Fed Dairy Manure. Environmental entomology. 37. 11-5. 10.1603/0046-225X(2008)37[11:DOBSFD]2.0.CO;2.
- [33] Sheppard, C., 1983. House fly and lesser house fly control utilizing the Black Soldier Fly in manure management systems for caged laying hens. Environ. Entomol. 12: 1439-1442.
- [34] Tomberlin, J.K., Adler, P.H., Myers, H.M., 2009. Development of the black soldier fly (Diptera: Stratiomyidae) in relation to temperature. J. Environ. Entomol. 38, 930-934.
- [35] Gullan, P.J., Cranston, P.S., 1994. The Insects: An Outline of Entomology. London: Chapman & Hall.
- [36] Lyn, J., Naikhwah, W., Aksenov, V., Rollo, C., 2010. Influence of two methods of dietary restriction on life history features and aging of the cricket *Acheta domesticus*. Age (Dordrecht, Netherlands). 33. 509-22. 10.1007/s11357-010-9195-z.
- [37] Jarosik, V., Kratochvil, L., Honek, A. & Dixon, A.F.G., 2004. A general rule for the dependence of developmental rate on temperature in ectothermic animals. Proceedings of the Royal Society of London Series B, Biological Sciences 27, S219–S221.
- [38] Booth, D.T., Kiddell K., 2007. Temperature and the energetics of development in the house cricket (*Acheta domesticus*). J Insect Physiol. 53(9):950-3. doi: 10.1016/j.jinsphys.2007.03.009. Epub 2007 Mar 30. PMID: 17481649.
- [39] Morales-Ramos, J., Rojas, M.G., Dossey, A., 2018. Age-dependent food utilisation of *Acheta domesticus* (Orthoptera: Gryllidae) in small groups at two temperatures. Journal of Insects as Food and Feed. 4. 51-60. 10.3920/JIFF2017.0062.
- [40] Woodring, J., Roe, R.M., Clifford, C., 1977. Relation of feeding, growth, and metabolism to age in the larval, female house cricket. Journal of insect physiology. 23. 207-12. 10.1016/0022-1910(77)90031-2.
- [41] umivale. Mutua colaborador con la seguridad social no15. (2020, 1 septiembre). GUÍA PARA EL MANEJO SEGURO DE CARRETILLAS ELEVADORAS Y TRANSPALETAS. [umivale.es. https://umivale.es/dam/web-corporativa/Documentos-prevenci-n-y-salud/equipos-de-trabajo/Gu-a-manejo-seguro-carretillas-elevadoras-y-transpaletas.pdf](https://umivale.es/dam/web-corporativa/Documentos-prevenci-n-y-salud/equipos-de-trabajo/Gu-a-manejo-seguro-carretillas-elevadoras-y-transpaletas.pdf)

- [42] Ricciardi, C., Baviera, C., 2016. Role of carbohydrates and proteins in maximizing productivity in *Alphitobius diaperinus* (Coleoptera tenebrionidae). *Journal of Zoology*. 99. 97-105. 10.19263/REDIA-99.16.13.
- [43] Trusk, A. M., Crissey, S. D., 1987. Comparison of calcium and phosphorus levels in crickets fed a high calcium diet versus those dusted with supplement. *Proceedings of the 7th Annual Dr. Scholl Conference on the Nutrition of Captive Wild Animals* (p. 93-99). Chicago, IL: Lincoln Park Zoological Gardens.
- [44] Szelei, J., Woodring, J., Goettel, M.S., Duke, G., Jousset, F.-X., Liu, K.Y., Zadori, Z., Li, Y., Styer, E., Boucias, D.G., Kleespies, R.G., Bergoin, M., Tijssen P., 2011. Susceptibility of North-American and European crickets to *Acheta domesticus* densovirus (AddNV) and associated epizootics. , 106(3), 0–399. doi:10.1016/j.jip.2010.12.009
- [45] Martins, A., Costelha, H., Neves, C., 2019 "Shop Floor Virtualization and Industry 4.0," in 19th IEEE International Conference on Autonomous Robot Systems and Competitions (ICARSC), Gondomar, Portugal, Apr 24-26 2019, NEW YORK: Ieee, in IEEE International Conference on Autonomous Robot Systems and Competitions ICARSC, pp. 225-230.
- [46] "Structure of the Administration Shell. Continuation of the development of the reference model for the industrie 4.0 component.," ed. Berlin, Germany: Platform Industrie 4.0, 2016.
- [47] Mihelj, M., Bajd, T., Ude, A., Lenarčič, J., Stanovnik, A., Munih, M., Šlajpah, S., 2019. *Robotics*, 2nd. ed. Cham: Springer International Publishing.
- [48] Van Meldert, B., De Boeck, L., 2016. Introducing autonomous vehicles in logistics: a review from a broad perspective, FEB Research Report KBI\_1618.
- [49] Bostelman, R., Teizer, J., Ray, S. J., Agronin, M., Albanese, D., 2014. Methods for improving visibility measurement standards of powered industrial vehicles", *Safety Science*, Article vol. 62, pp. 257-270, doi: 10.1016/j.ssci.2013.08.020.



# COROSECT

 Maastricht University



**CERTH**  
CENTRE FOR RESEARCH & TECHNOLOGY HELLAS

 University of Applied Sciences  
**HOCHSCHULE  
EMDEN·LEER**

  
**Luke**  
LUONNONVARAKESKUS

  
**tecnova**  
CENTRO TECNOLÓGICO

**KU LEUVEN**   
CENTRE FOR IT & IP LAW

**Atos**

 **Robotnik**

**AGV R**

 **NASEKOMO**



**ENTOMOTECH**  
Exploiting the Natural Potential

**ENTOCYCLE**

 **Italian Cricket farm**

 **invertapro**

**FieldLab ROBOTICS**

**f/h**

**AgriFood**   
Lithuania

  
**CIHEAM  
BARI**

**OAMK**  
OULU UNIVERSITY OF  
APPLIED SCIENCES



This project has received funding from the European Union's Horizon 2020 research and innovation programme under grant agreement No 101016953